

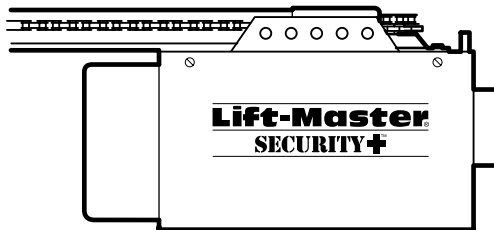

# Garage Door Opener Owner's Manual

Model Series 1200  
For Residential Use Only



Model 1256R - 1/2HP  
Model 1246R - 1/3HP

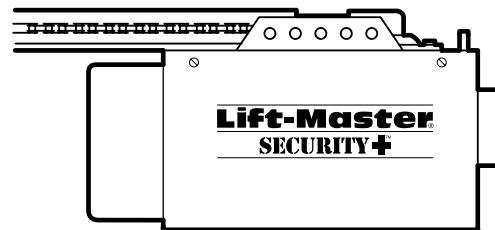

Model 1255R - 1/2HP  
Model 1245R - 1/3HP

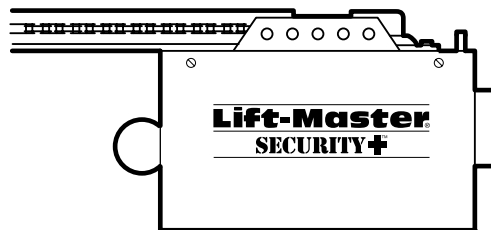

Model 1240R - 1/4HP

- Please read this manual and the enclosed safety materials carefully!
- Fasten the manual near the garage door after installation.
- The door WILL NOT CLOSE unless the Protector System<sup>®</sup> is connected and properly aligned.
- Periodic checks of the opener are required to ensure safe operation.
- The model number label is located on the front panel of your opener.

CONTENTS	PAGE	CONTENTS	PAGE
A review of safety alert symbols .....	2	Attach manual release rope and handle .....	19
You'll need tools .....	3	Electrical requirements .....	20
Safety information regarding garage door locks and ropes.....	3	The Protector System® .....	21
Testing your garage door for sticking, binding and balance .....	3	Install the safety reversing sensor .....	22, 23
Illustration of sectional door installation .....	4	Fasten door bracket (sectional door) .....	24
Illustration of one-piece door installation .....	5	Fasten door bracket (one-piece door).....	25
Carton inventory .....	6	Connect door arm to trolley (sectional door) .....	26
Hardware inventory .....	7	Connect door arm to trolley (one-piece door) .....	27
<b>Assembly Section - Pages 8 – 11</b>		<b>Adjustment Section - Pages 28 – 30</b>	
Fasten T-rail to opener .....	8, 9	Travel limit adjustments .....	28
Attach chain to sprocket, install sprocket cover....	8	Force adjustments .....	29
Attach chain spreader, re-install chain .....	10	Test the Protector System® .....	30
Tighten the chain .....	11	Test the safety reverse system .....	30
<b>Installation Section - Pages 11 – 27</b>		Operation safety instructions .....	31
Installation safety instructions.....	11	Care of your opener .....	31
Determine header bracket location		Maintenance schedule .....	31
Sectional door.....	12	Operation of your opener .....	32
One-piece door.....	13	Receiver and remote control programming.....	33
Install header bracket .....	14	Having a problem?.....	34, 35
Attach the T-rail to header bracket .....	15	Repair parts, rail assembly .....	36
Position the opener.....	16	Repair parts, installation .....	36
Hang the opener.....	17	Repair parts, opener assembly .....	37
Install the door control .....	18	Accessories.....	38
Install the light(s) and lens(es).....	19	Index .....	39
		How to order repair parts .....	40
		Maintenance agreement .....	40
		Warranty .....	40

**Start by reviewing these important safety alert symbols**

When you see these Safety Symbols on the following pages, they will alert you to the possibility of *serious injuries or death* if you do not comply with the corresponding instructions. The hazard may come from something mechanical or from electric shock. *Read the instructions carefully.*



**WARNING**

**Mechanical**



**WARNING**

**Electrical**

When you see this Safety Symbol on the following pages, it will alert you to the possibility of damage to your garage door and/or the garage door opener if you do not comply with the corresponding instructions. *Read the instructions carefully.*



**CAUTION**

This garage door opener is designed and tested to offer safe service provided it is installed, operated, maintained and tested in strict accordance with the safety instructions contained in this manual.

# You'll Need Tools

During assembly, installation and adjustment of the opener, instructions will call for hand tools shown below.

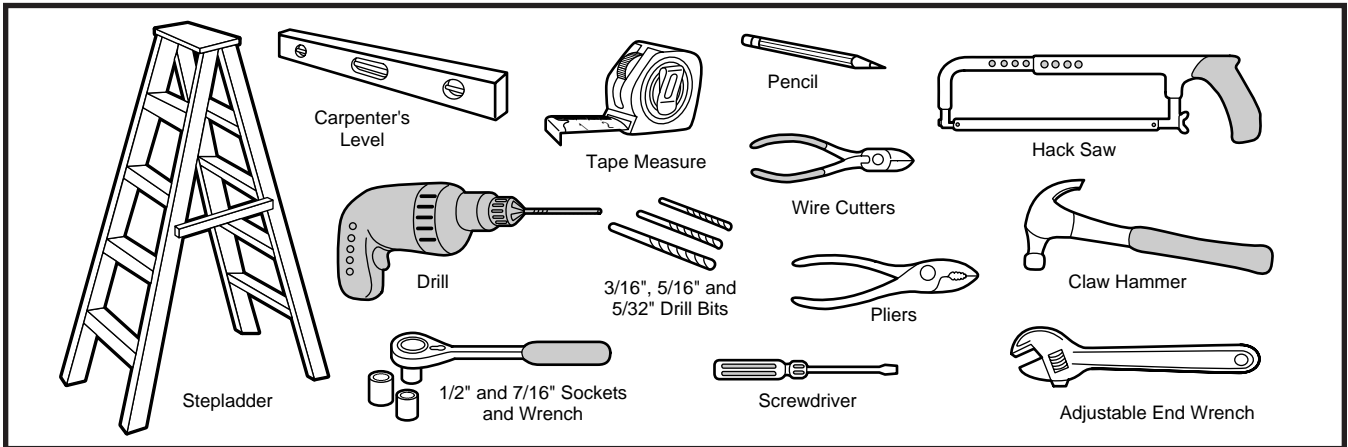

## WARNING

*An unbalanced garage door might not reverse when required and someone under the door could be seriously injured or killed.*

If your garage door binds, sticks or is out of balance, call for professional garage door service. *Garage doors, door springs, cables, pulleys, brackets and their hardware are under extreme tension and can cause serious injury or death. Do not try to loosen, move or adjust them yourself!*

*Ropes left on a garage door could cause someone to become entangled and killed. Remove all ropes connected to the door before installing and operating the opener.*

## CAUTION

To avoid damage to the garage door and opener, disable locks before installing and operating the opener. Use a wood screw or nail to hold locks in the "open" (unlocked) position.

Operation at other than 120V 60 Hz will cause opener malfunction and damage.

Before you begin, complete the following test to make sure your door is balanced, and is not sticking or binding:

- Lift the door about halfway as shown. Release the door. It should stay in place, supported entirely by its springs.
- Raise and lower the door to see if there is any binding or sticking.

Identify the type and height of your door and any special conditions that exist and any additional materials that may be required by referring to the lists on page 4 or page 5.

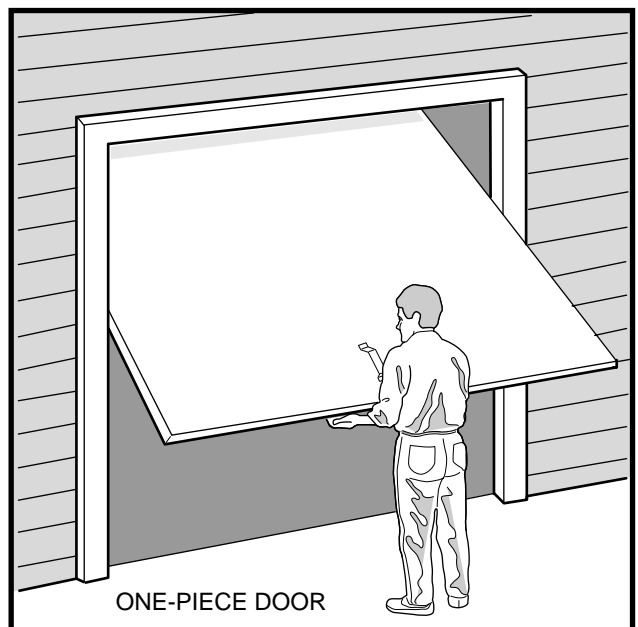
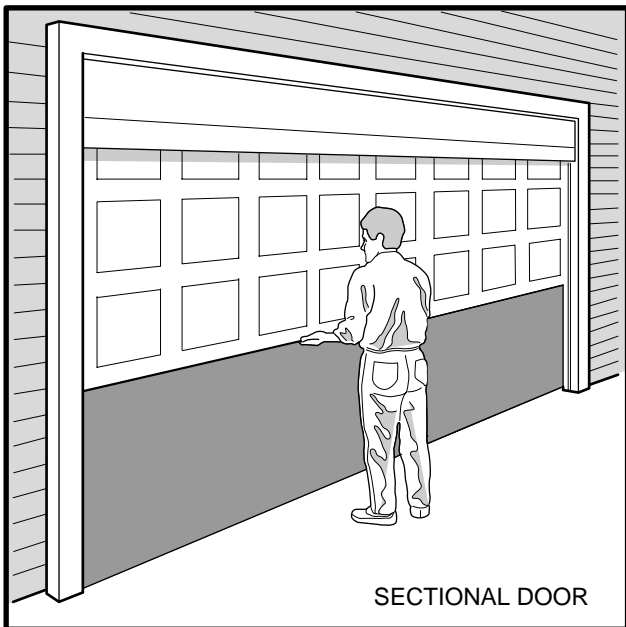

## Sectional Door Installation

Before you begin, survey your garage area to see whether any of the conditions below apply to your installation.

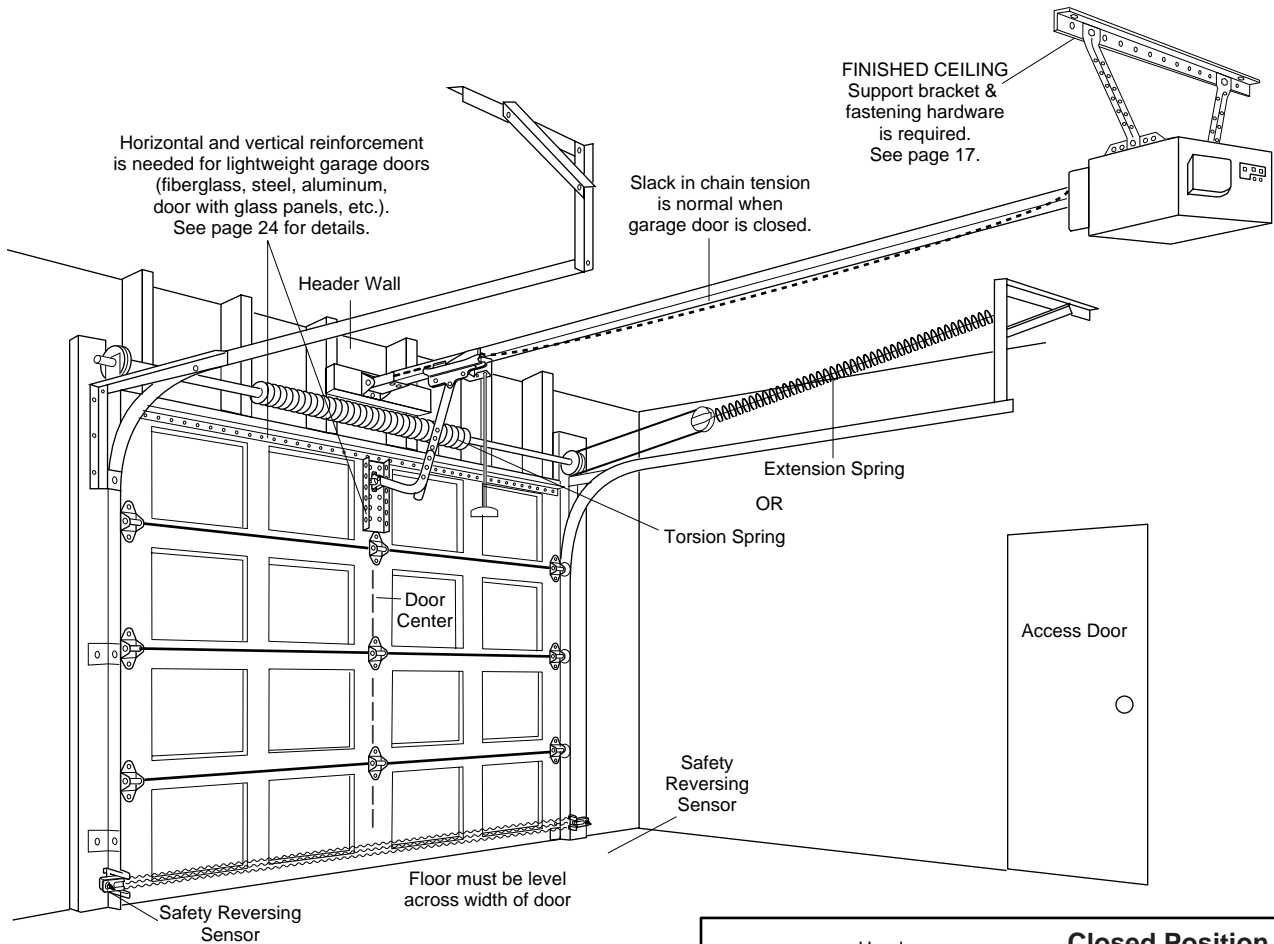

Based on your particular requirements, there are several installation steps which might call for materials and/or hardware not included in the carton.

- Step 1, page 12 - Look at the wall or ceiling above the garage door. The header bracket *must* be securely fastened to structural supports.
- Step 5, page 17 - Do you have a finished ceiling in your garage? If so, a support bracket and additional fastening hardware may be required.
- Safety reversing sensor, page 21 - Depending upon garage construction, wood blocks may need to be fastened to mounting locations before sensors are installed.
- Step 10, page 22 - Alternate floor mounting of the safety reversing sensor will require hardware not provided.
- Step 11, page 24 - Do you have a steel, aluminum, fiberglass or glass panel door? If so, horizontal and vertical reinforcement is required.
- Look at the garage door where it meets the floor. **It must close on the floor all the way across. Other-wise, the safety reverse system may not work properly.** See page 30. Floor or door should be repaired.
- If your door is more than 7 feet high, see longer rails available on page 38.

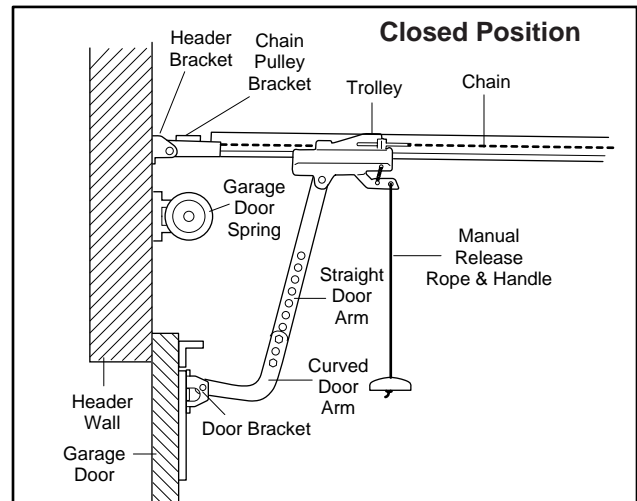

- The opener can be installed within 2 feet to the left or right of the door center if there is a torsion spring or center bearing plate in the way of the header bracket or door bracket area. *If your door has extension springs, the opener must be installed in the center of the door.* See pages 12 and 24.
- Do you have an access door in addition to the garage door? If not, Model 1702 Outside Quick Release is required. See page 38.

**You may find it helpful to refer back to this page as you proceed with the installation of your opener.**

## One-Piece Door Installation

Before you begin, survey your garage area to see whether any of the conditions below apply to your installation.

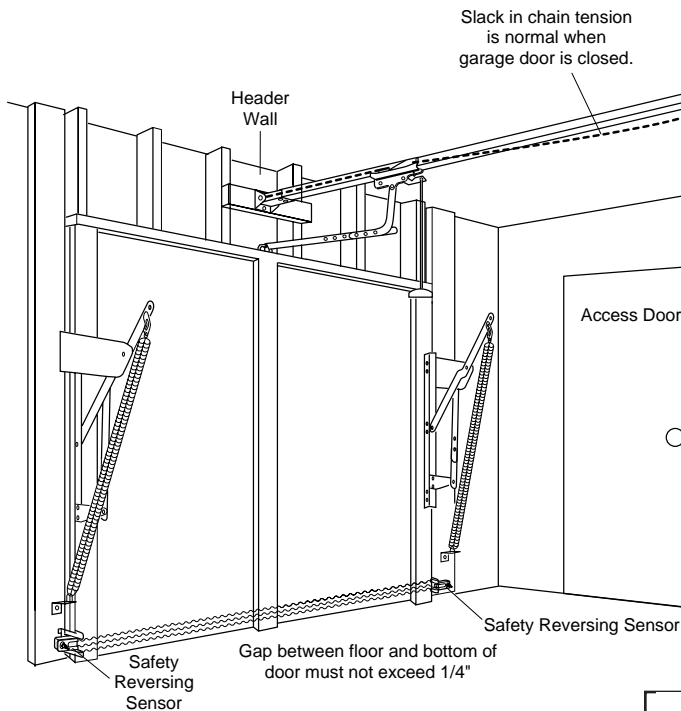

## One-Piece Door without Track

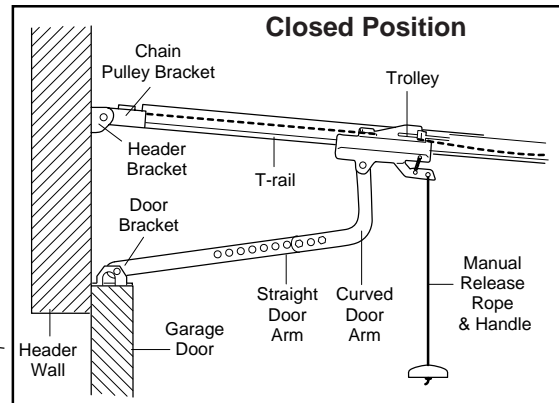
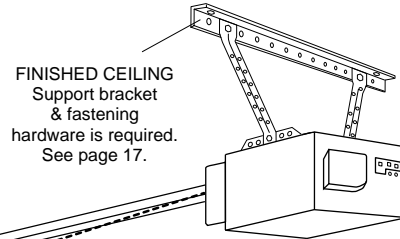

Based on your particular requirements, there are several installation steps which might call for materials and/or hardware not included in the carton.

- Step 1, page 13 - Look at the wall or ceiling above the garage door. The header bracket *must* be securely fastened to structural supports.
- Step 5, page 17 - Do you have a finished ceiling in your garage? If so, a support bracket and additional fastening hardware (not supplied) may be required
- Safety reversing sensor, page 21 - Depending on garage construction, wood blocks may need to be securely fastened to mounting locations before sensors are installed.
- Step 10, page 22 - Alternate floor mounting of the safety reversing sensor will require hardware that is not provided.
- Step 11, page 25 - Generally, a one-piece door does not require reinforcement. If your door is lightweight, you can refer to the information relating to sectional doors on page 24.
- Step 11, page 25 - Depending on your door's construction, you might need additional mounting hardware for the door bracket.
- Do you have an access door in addition to the garage door? If not, Model 1702 Outside Quick Release is required. See page 38.
- **The gap between the bottom of the garage door and the floor cannot exceed 1/4". Otherwise, the safety reverse system may not work properly.** See page 30. The floor or the door should be repaired.

## One-Piece Door with Track

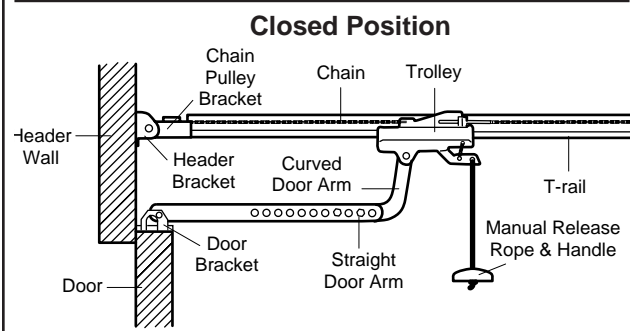
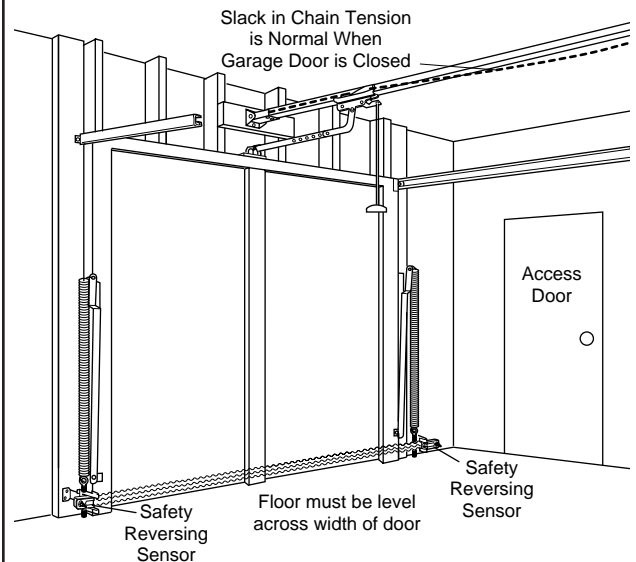

You may find it helpful to refer back to this page as you proceed with the installation of your opener.

# Carton Inventory

Your garage door opener is packaged in two cartons which contain all parts illustrated below. If anything is missing, carefully check the packing material. Parts may be "stuck" in the foam. Hardware for installation is shown on page 7.

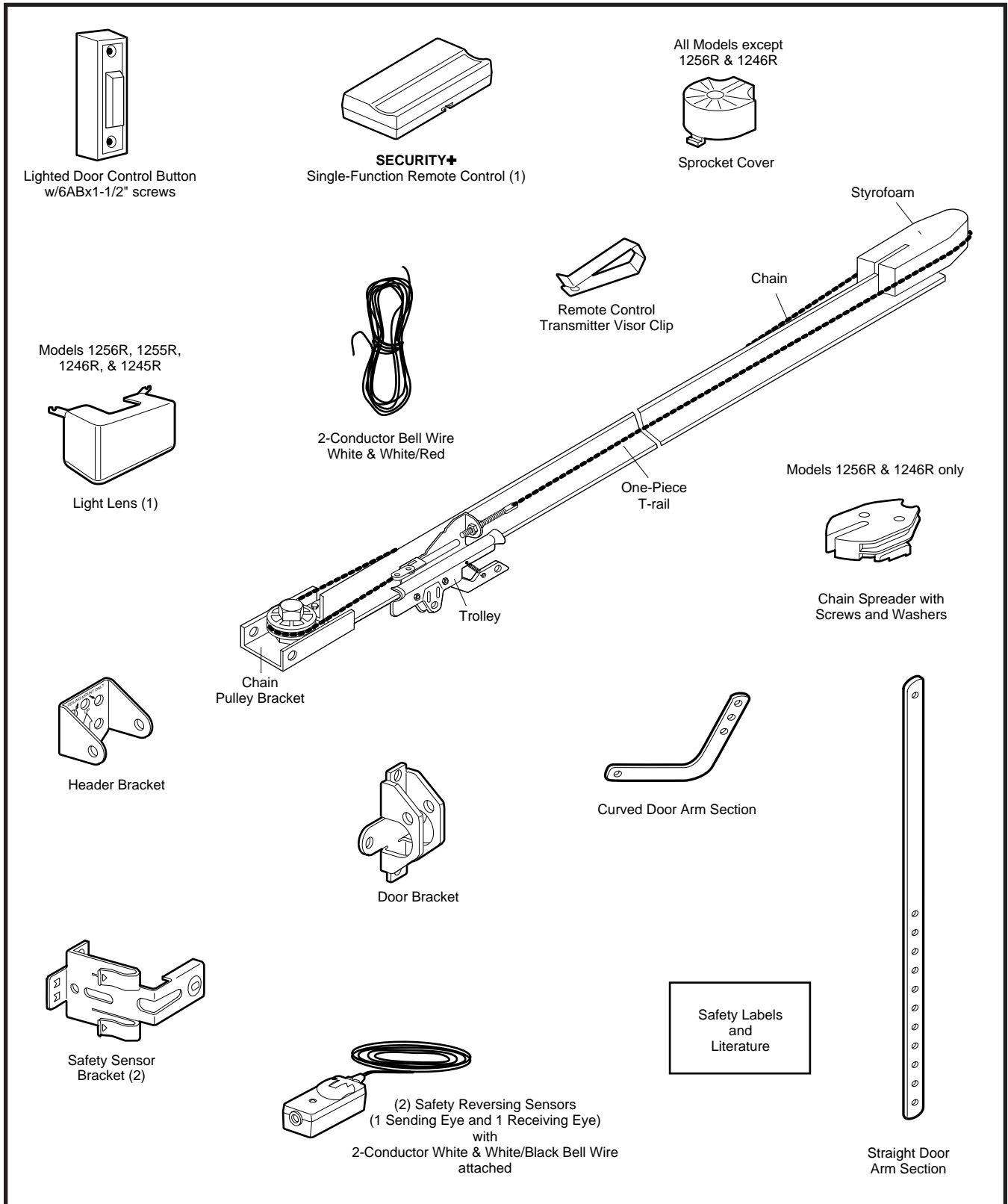

Group all hardware found in all packages contained in the opener carton into the two kits illustrated below.

### Installation Hardware

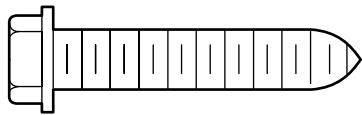

Lag Screw  
5/16"-9 x1-5/8" (2)

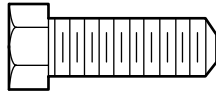

Hex Screw  
5/16"-18x7/8" (4)

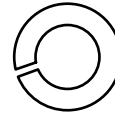

Lock Washer 5/16" (6)



Rail Grease



Lag Screw  
5/16"-18x1-7/8" (2)



Handle



Nut 5/16"-18 (6)



Ring Fastener (3)

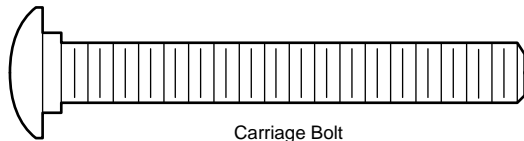

Carriage Bolt  
5/16"-18x2-1/2" (2)

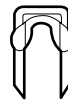

Insulated Staples (10)

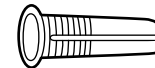

Dry Wall Anchors (2)

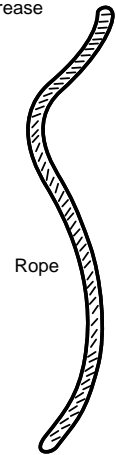

Rope

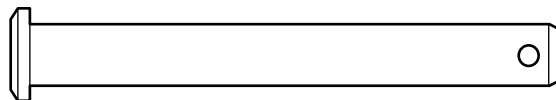

Clevis Pin  
5/16"x2-3/4" (1)

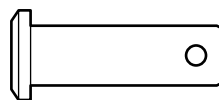

Clevis Pin  
5/16"x1" (1)

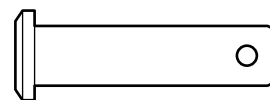

Clevis Pin  
5/16"x1-1/4" (1)

### Safety Reversing Sensor Installation Hardware

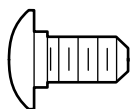

Carriage Bolts  
1/4"-20x1/2" (2)

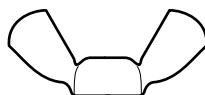

Wing Nut (2)

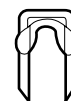

Insulated  
Staples (20)

## Assembly Step 1

### Attach the T-rail to the Opener

For Models 1255R, 1245R, and 1240R

See page 9 for Models 1256R and 1246R.

- Remove the two washered screws mounted in top of opener
- Align T-rail at an angle with opener so one hole in T-rail and opener line up.
- Thread one of the washered screws part way in.

**Use only these screws! Use of any other screws will cause serious damage to door opener.**

- Align T-rail and styrofoam over opener sprocket. Cut tape from T-rail, chain and styrofoam.
- **REMOVE STYROFOAM.**



## CAUTION

To fasten rail, use only those screws mounted in top of the opener. Any other screws will cause serious damage to the opener.

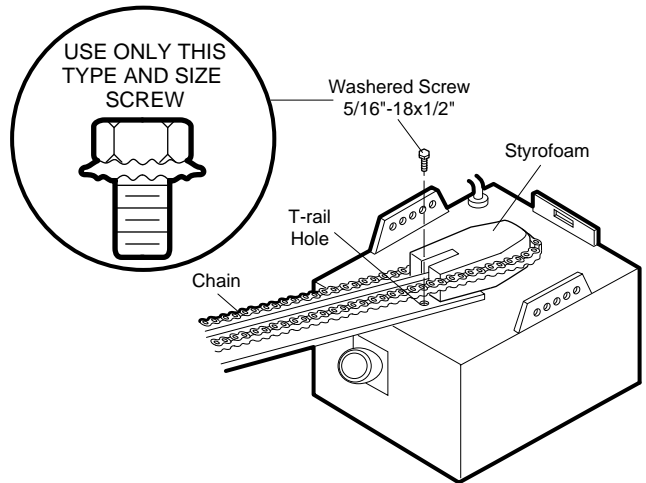

## Assembly Step 2

### Attach Chain to Sprocket and Install Sprocket Cover

For Models 1255R, 1245R, and 1240R

- Position chain over the opener sprocket. If necessary, loosen the outer nut on the trolley to obtain more chain slack.
- Insert the second washered screw.  
**CAUTION: Use only the screw previously removed from opener!**
- Tighten both screws securely through the T-rail into the opener as shown.

**Install the sprocket cover:**

- Insert the back tab in the opener slot. Squeeze the cover slightly and insert the front tab in the slot on the mounting plate.

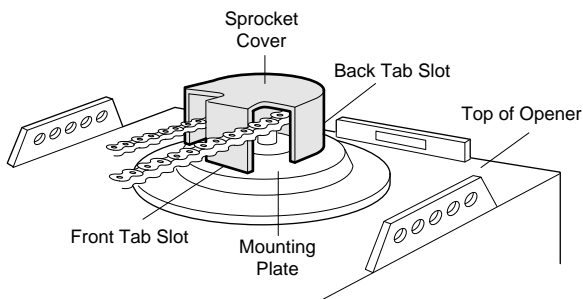

## WARNING

Serious injury can result if fingers become entangled in moving opener sprocket. Attach sprocket cover securely. Never operate opener while your hand is near the opener sprocket.

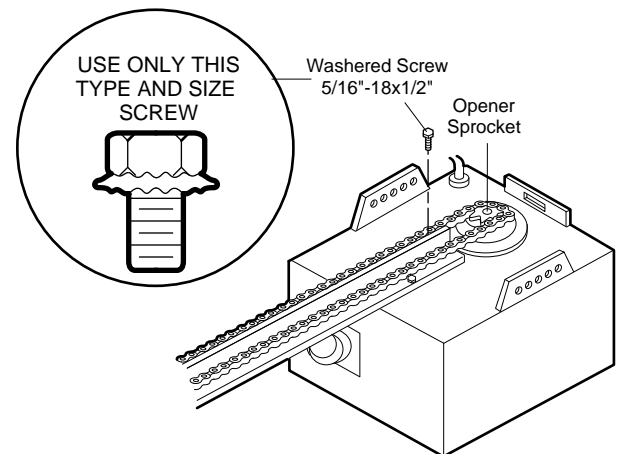

**Proceed to Assembly Step 3, page 11.**

## Assembly Step 1

### Attach the T-rail to the Opener

For Models 1256R and 1246R only

- Place the opener on packing material to protect the cover.
- Remove the (2) 5/16"-18x1/2" washered screws mounted in the top of the opener.
- Align T-rail and styrofoam over opener sprocket.

- Cut tape from T-rail, chain and styrofoam. Remove styrofoam and pull the chain back (away from mounting plate)
- Fasten the rail with the (2) washered screws previously removed. Tighten securely.

**Remember to use only these screws! Any other screws will cause serious damage to the opener.**



## CAUTION

To fasten rail, use only those screws mounted in the top of the opener. Any other screws will cause serious damage to the opener.

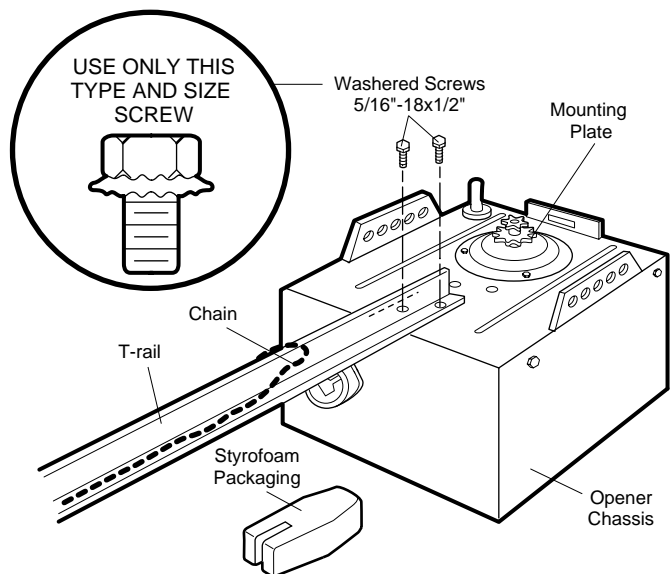
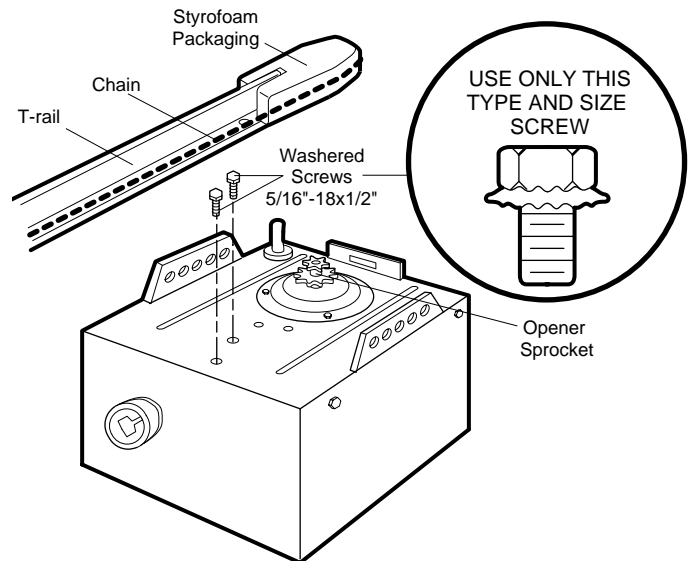

## Assembly Step 2

### Attach the Chain Spreader and Re-install the Chain

For Models 1256R and 1246R only

- Line up the holes in the chain spreader with the holes in the opener as shown. The slot in the chain spreader must fit over the T-rail flange.
- Securely fasten the chain spreader with the hardware provided.

- Remove the trolley threaded shaft from the trolley by loosening the inner nut and lock washer.

- Guide the chain around the selected groove in the chain spreader (to engage either the 8-tooth sprocket or the 6-tooth sprocket) as shown.

- Continue dispensing the chain forward to the trolley. Reconnect the trolley to the trolley threaded shaft. Proceed to page 11 for chain tightening instructions.



## WARNING

Serious injury can result if fingers become entangled in moving opener sprocket. Attach sprocket cover securely. Never operate opener while your hand is near the opener sprocket.

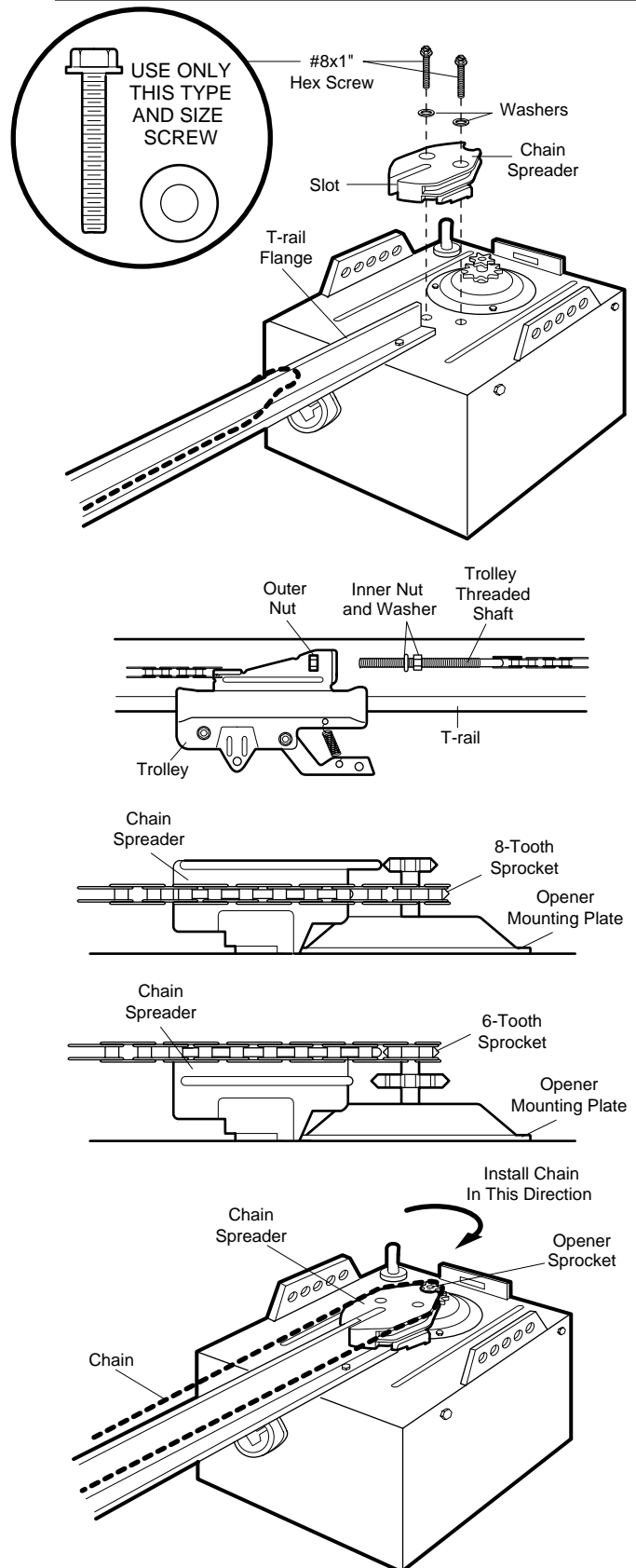

## Assembly Step 3

### Tighten the Chain

(All Models)

- Spin the inner nut and lock washer down the threaded shaft, away from the trolley.
- To tighten the chain, turn outer nut in the direction shown. **As you turn the nut, keep the chain from twisting.**
- When the chain is approximately 1/2" above the base of the T-rail at its midpoint, re-tighten the inner nut to secure the adjustment.

**Sprocket noise can result if chain is either too loose or too tight.**

When installation is complete, you may notice some chain droop with the door closed. This is normal. If the chain returns to the position shown when the door is open, *do not re-adjust the chain.*

**NOTE:** During future maintenance, **ALWAYS** pull the manual release handle to disconnect trolley before adjusting chain.

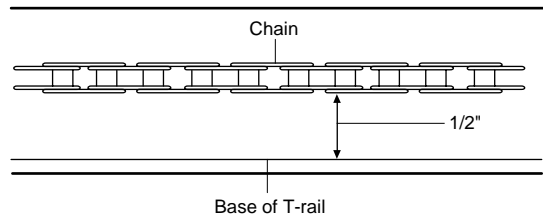
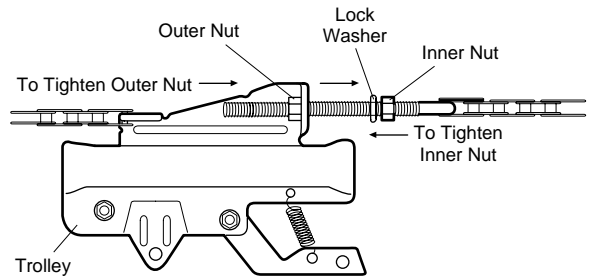

You have now finished assembling your garage door opener. Please read the following warnings before proceeding to the installation section.

## IMPORTANT INSTALLATION INSTRUCTIONS



**WARNING**



**WARNING**

**To reduce the risk of severe injury or death to persons:**

1. **READ AND FOLLOW ALL INSTALLATION INSTRUCTIONS**
2. Install only on a properly balanced and lubricated garage door. *An improperly balanced door may not reverse and could result in severe injury or death.* Repairs to cables, spring assemblies and other hardware must be made by a professional service person before installing opener.
3. Disable all locks and remove all ropes connected to the garage door before installing the opener. *Ropes connected to a garage door can cause entanglement and death.*
4. If possible, install door opener 7 feet or more above floor with the manual release handle mounted 6 feet above the floor.
5. Do not connect the opener to power source until instructed to do so.
6. Locate the Door Control within sight of the door at a minimum height of 5 feet where small children cannot reach and away from all moving parts of the door.
7. Install the User Safety Instruction Label on the wall adjacent to the control button and the Maintenance Instruction Label in a prominent location on the inside of the garage door.
8. Upon completion of the installation, the door must reverse when it comes in contact with a one-inch high object (or a 2x4 laid flat) on the floor.
9. Do not wear watches, rings or loose clothing while installing or servicing an opener. Jewelry or loose clothing can be caught in the mechanism of the garage door or the opener.

## Installation Step 1

### Determine Header Bracket Location

Installation procedures vary according to garage door types. Follow the instructions which apply to your door.

#### SECTIONAL Doors and ONE-PIECE Door With Track

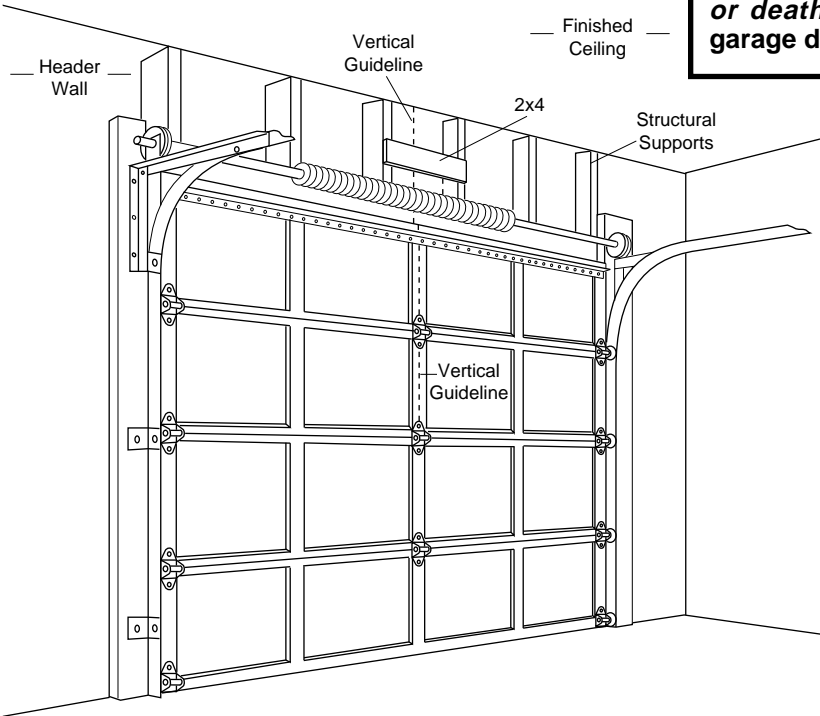

## WARNING

If the header bracket is not rigidly fastened to a structural support on the header wall or ceiling, the safety reverse system may not work properly (see page 30). *The door might not reverse when required, and could cause serious injury or death.*

The garage door springs, cables, pulleys, brackets and their hardware are under extreme tension. *Do not attempt to loosen, move or adjust them yourself. Serious personal injury or death could result. Call for professional garage door service.*

- Close the door and mark the inside vertical centerline of the garage door.
- Extend the line onto the header wall above the door.

**Remember, you can fasten the header bracket within 2 feet to the left or right of the door center *only* if a torsion spring or center bearing plate is in the way; or you can attach it to the ceiling (refer to page 14) when clearance is minimal. (It may be mounted on the wall upside down if necessary, to gain approximately 1/2".)**

*If you need to install the header bracket on a 2x4 (on wall or ceiling), use lag screws (not supplied) to securely fasten the 2x4 to structural supports as shown here and on page 13.*

- Open your door to the highest point of travel as shown. Draw an intersecting horizontal line on the header wall 2" above the high point. This height will provide travel clearance for the top edge of the door.

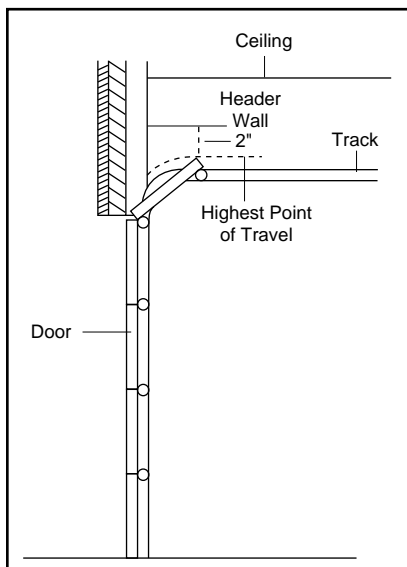

Sectional door with curved track

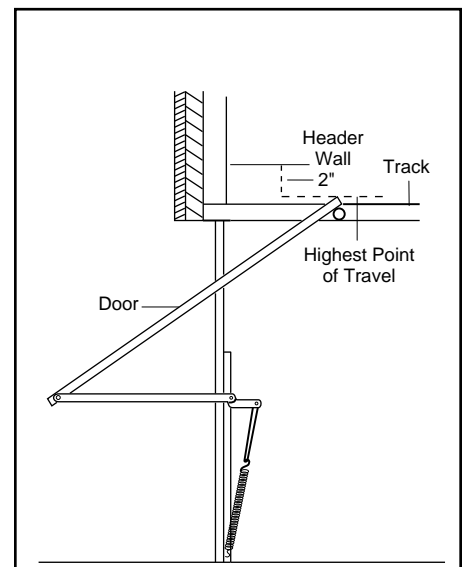

One-piece door with horizontal track

Proceed to Step 2, page 14.

# ONE-PIECE Door Without Track

Read the Safety Instructions on page 12. They also apply to doors without tracks.

- Close the door and mark the inside vertical centerline of your garage door. Extend the line onto the header wall above door.  
If headroom clearance is minimal, you can install the header bracket on the ceiling. See page 14.
- *If you need to install the header bracket on a 2x4 (on wall or ceiling), use lag screws (not supplied) to securely fasten the 2x4 to structural supports as shown.*

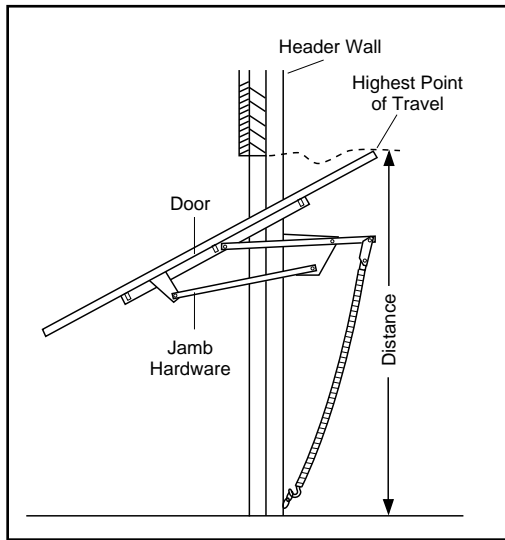
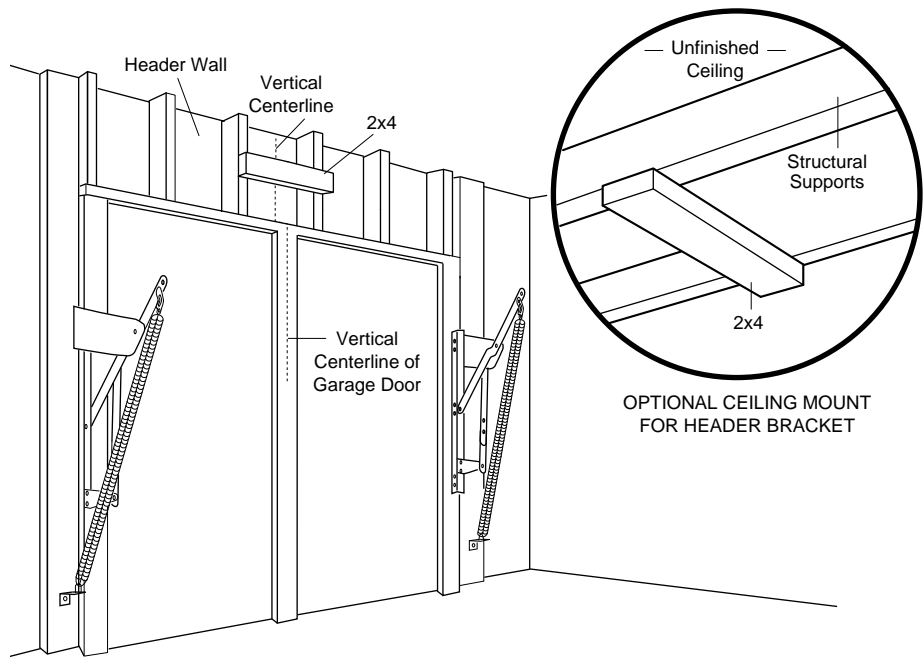

**One-piece door without track jamb hardware**

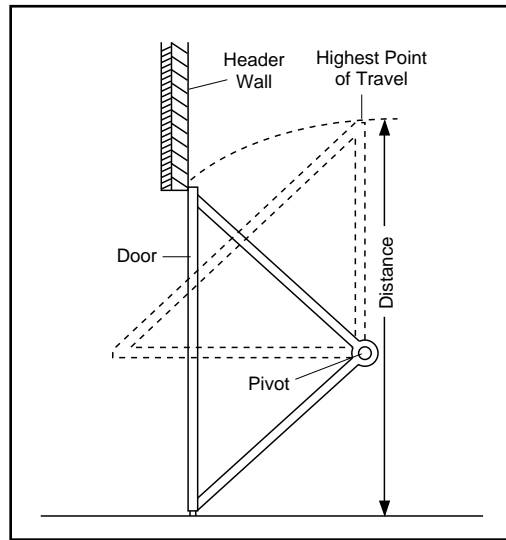

**One-piece door without track pivot hardware**

- Open your door to the highest point of travel as shown. Measure the distance from the top of the door to the floor. Subtract the actual height of the door. Add 8" to the remainder. (See Example).
  - Close the door and draw an intersecting horizontal line on the header wall at the determined height.
- If the total number of inches exceeds the height available in your garage, use the maximum height possible, or refer to page 14 for ceiling installation.**

**EXAMPLE**

Distance from top of door (at highest point of travel) to floor.....	92"
Actual height of door .....	- 88"
Remainder .....	4"
Add .....	+ 8"
Bracket height on header wall .....	= 12"

(Measure UP from top of CLOSED door.)

**Proceed to Step 2, page 14.**

## Installation Step 2

### Install the Header Bracket

You can attach the header bracket either to the wall above the garage door, or to the ceiling. Follow the instructions which will work best for your particular requirements.

#### Fasten the Header Bracket to the Wall

- Center the bracket on the vertical guideline with the bottom edge of the bracket on the horizontal line as shown (with the arrow pointing toward the ceiling).

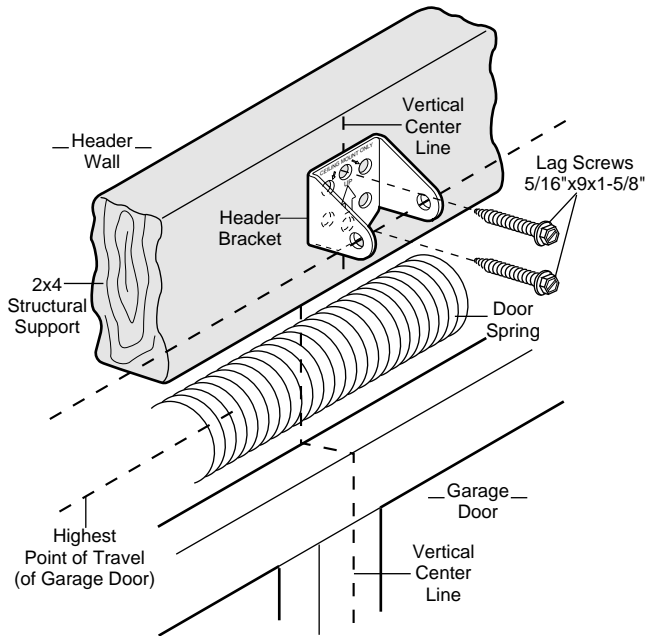

- Mark either set of bracket holes (do not use the holes designated for ceiling mount). Drill 3/16" pilot holes and fasten the bracket securely to a structural support with the hardware provided.

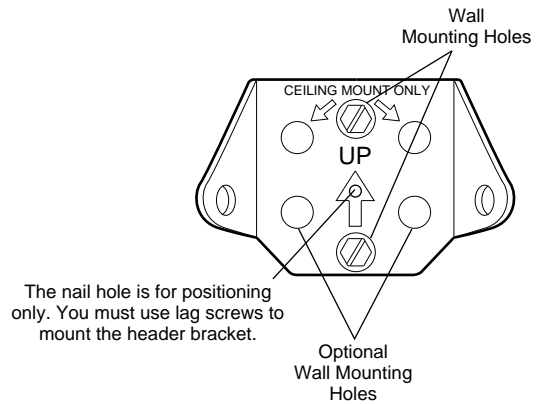

#### Hardware Shown Actual Size

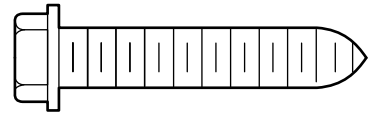

Lag Screw  
5/16"-9 x 1-5/8"

#### Fasten the Header Bracket to the Ceiling

- Extend the vertical guideline onto the ceiling as shown.
- Center the bracket on the vertical mark, no more than 6" from the wall. Make sure the arrow is pointing toward the wall. The bracket can be mounted flush against the ceiling when clearance is minimal.
- Mark holes designated for ceiling mount only. Drill 3/16" pilot holes and fasten bracket securely to a structural support with the hardware provided.

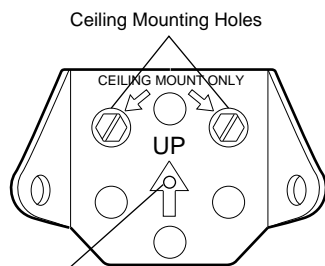

The nail hole is for positioning only. You must use lag screws to mount the header bracket.

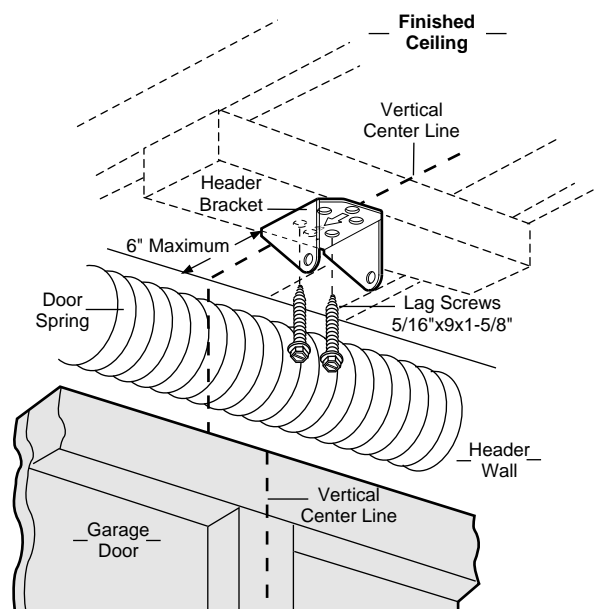

## Installation Step 3

### Attach the T-rail to the Header Bracket

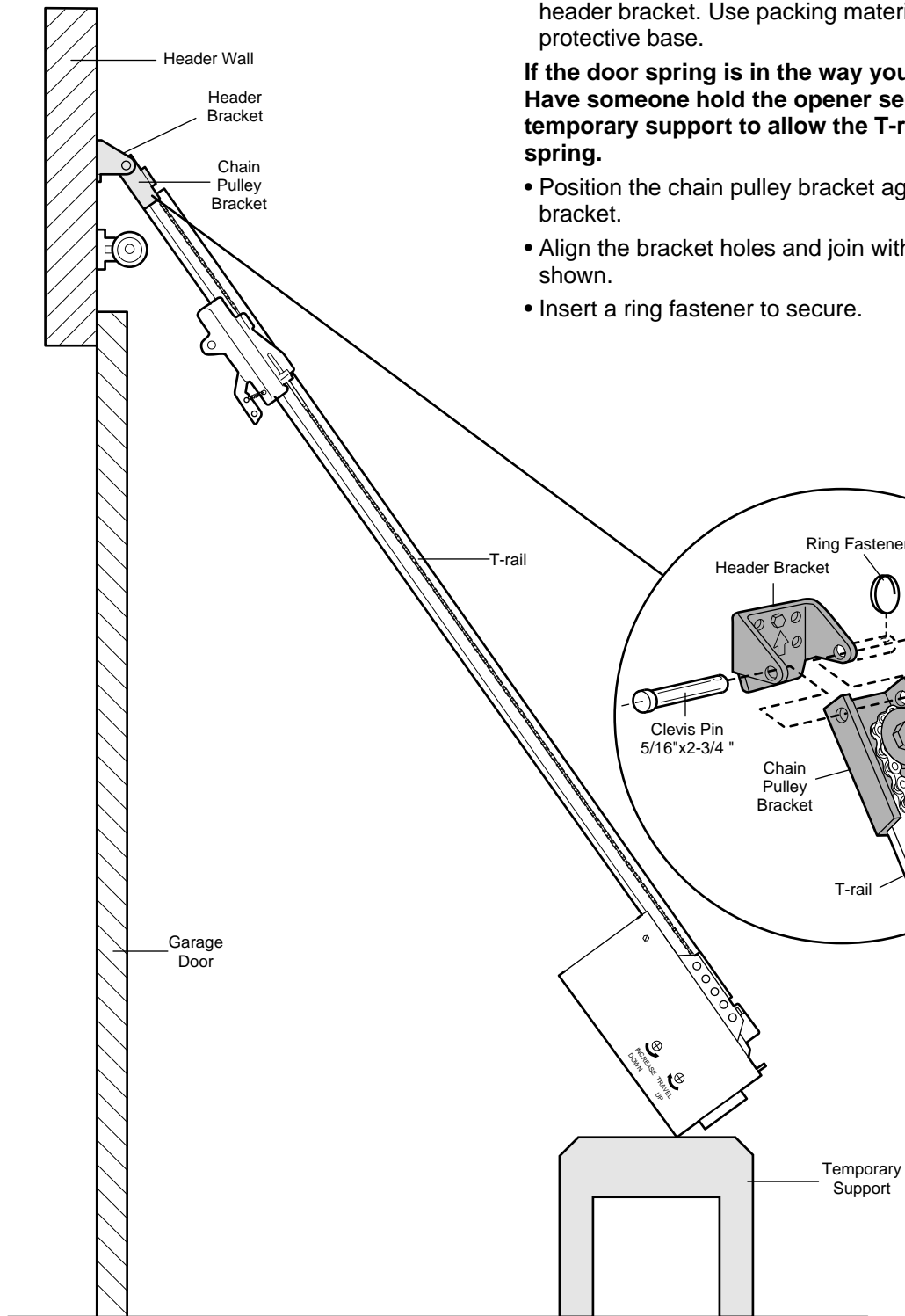

- Position the opener on the garage floor below the header bracket. Use packing material as a protective base.

**If the door spring is in the way you'll need help. Have someone hold the opener securely on a temporary support to allow the T-rail to clear the spring.**

- Position the chain pulley bracket against the header bracket.
- Align the bracket holes and join with a clevis pin as shown.
- Insert a ring fastener to secure.

#### Hardware Shown Actual Size

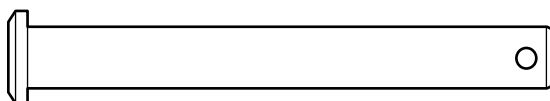

Clevis Pin  
5/16"x2-3/4"



Ring Fastener

## Installation Step 4

### Position the Opener

Follow instructions which apply to your door type as illustrated.



## CAUTION

To prevent damage to steel, aluminum, fiberglass or glass panel doors, do not rest the opener on the door without using a 2x4.

### SECTIONAL Door & ONE-PIECE Door with Track

A 2x4 laid flat is convenient for setting an ideal door-to-T-rail distance.

- Raise the opener onto a stepladder.

**You will need help at this point if the ladder is not tall enough.**

- Open the door all the way and place a 2x4 laid flat on the top section beneath the T-rail.

- **If the top panel hits the trolley when you raise the door, pull down on the trolley release arm to disconnect inner and outer sections. The trolley can remain disconnected until Step 12 is completed.**

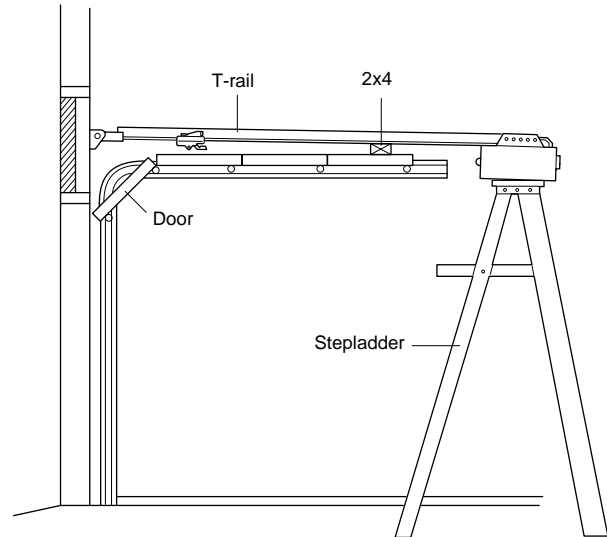
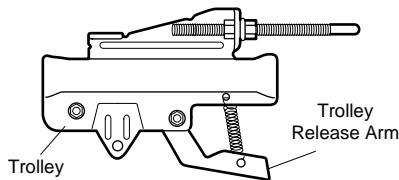

### ONE-PIECE Door without Track

- With the door fully open and parallel to the floor, measure the distance from the floor to the top of the door.
- Using a stepladder as a support, raise the opener to the same distance as the door from the floor (it will be at a slight angle as shown).
- The top of the door should be level with the top of the opener. Do not position the opener more than 2" above this point.

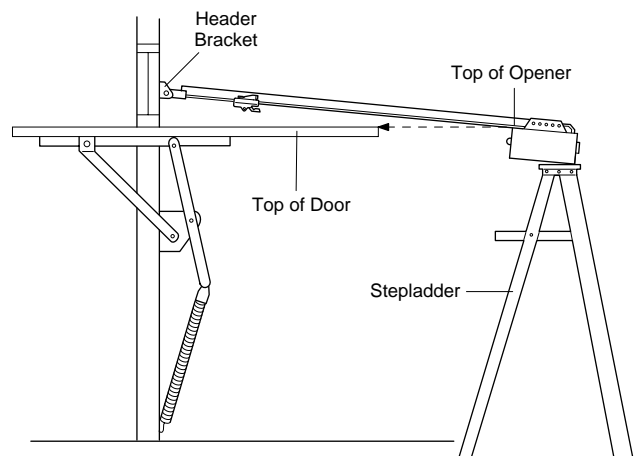

## Installation Step 5

### Hang the Opener

Two representative installations are shown. Yours may be different. Hanging brackets should be angled, Figure 1, to provide rigid support. On finished ceilings, Figure 2, attach a sturdy metal bracket to structural supports before installing the opener. The bracket and fastening hardware are not supplied.

- Measure the distance from *each* side of the opener to the structural support.
- Cut both pieces of the hanging bracket to required lengths.
- Drill 3/16" pilot holes in the structural supports.
- Attach one end of each bracket to a support with 5/16"x18x1-7/8" lag screws.
- Fasten the opener to the hanging brackets with 5/16"-18x7/8" hex screws, lock washers and nuts.
- Check to make sure the T-rail is centered over the door (or in line with the header bracket if the bracket is not centered above the door).
- Remove the 2x4. Operate the door manually. If the door hits the rail, raise the header bracket.

Grease the top and underside of the rail surface where the trolley slides. A tube of grease is supplied.



#### Hardware Shown Actual Size

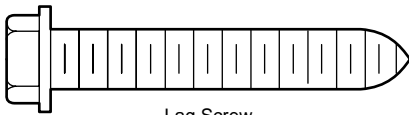

Lag Screw  
5/16"-18x1-7/8"

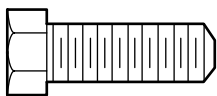

Hex Screw  
5/16"- 18x7/8"

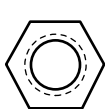

Nut 5/16"-18

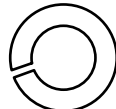

Lock Washer 5/16"



## WARNING

The opener could fall and injure someone if it is not properly secured. Fasten the opener securely to structural supports of the garage.

Figure 1

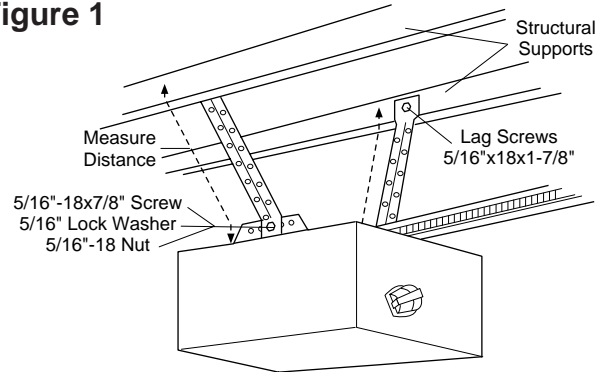
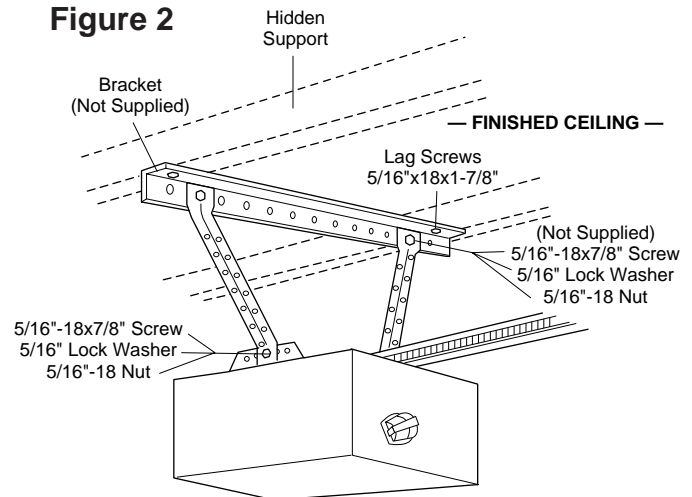

Figure 2



## Installation Step 6

### Install the Door Control

- **Locate the Door Control within sight of the door at a minimum height of 5 feet where small children cannot reach, and away from all moving parts of the door and door hardware.** Fasten the Door Control Button securely with 6ABx1-1/2" screws. If installing into drywall, drill 5/32" holes and use the anchors provided.
- Strip 1/4" of insulation from one end of the bell wire; connect the wire to the two screw terminals on the back of the Door Control by color: white to 2, and white/red to 1.
- Run the bell wire up the wall and across the ceiling to the opener. Use insulated staples to secure the wire in several places. Be careful not to pierce the wire with a staple, thereby resulting in a short.
- Receiver terminal screws and the antenna are located on the back panel of the opener. Position the antenna wire as shown.
- Then connect the bell wire to the opener terminal screws: white to 2 and white/red to 1.
- **Remember to affix the User Safety Instruction label to the wall near the Door Control, and the Maintenance Instruction label in a prominent location on the inside of the garage door.**

If the label adhesive will not adhere to your garage wall surface (or becomes loose with time) use tacks to secure the label alongside the Door Control.

Page 32 explains how to operate the opener using the Door Control.

#### Hardware Shown Actual Size

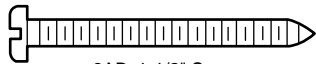

6ABx1-1/2" Screw  
Lighted Door Control Button

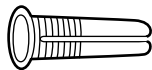

Dry Wall Anchors

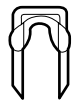

Insulated Staples



## WARNING

Children operating or playing with a garage door opener can injure themselves or others. *The garage door could close and cause serious injury or death.*

Install the Door Control (or any additional push buttons) out of the reach of children and away from all moving parts of the door and door hardware, *but where the garage door is visible.* Do not allow children to operate the push button(s) or the remote control transmitter(s).

*A moving garage door could injure someone under it.* Activate the opener only when the door is properly adjusted, you can see it clearly, and there are no obstructions to door travel.

**Do NOT connect the power and operate the opener at this time.** The trolley will travel to the full open position but will not return to the close position until the sensor beam is connected and properly aligned.

See Safety Reversing Sensor instructions beginning on page 21.

#### Outside Keylock Accessory Connections

To opener terminal screws: white to 2; white/red to 1

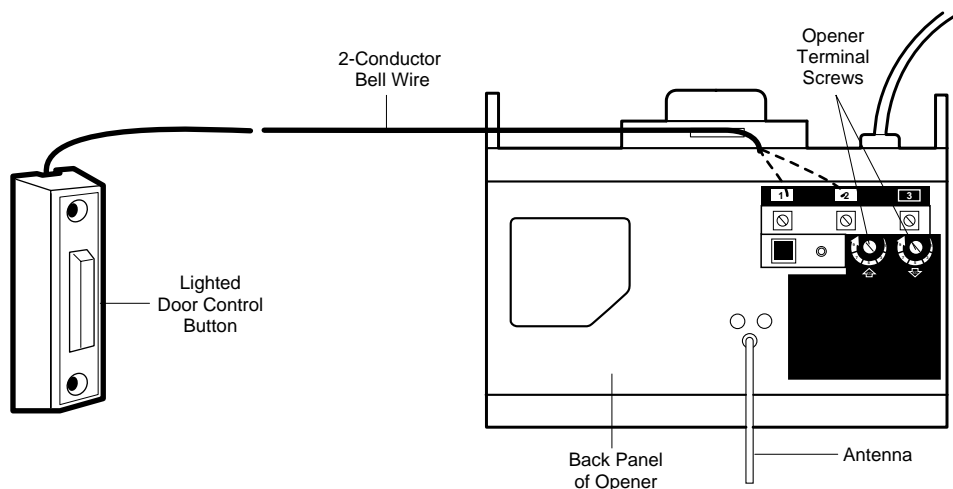
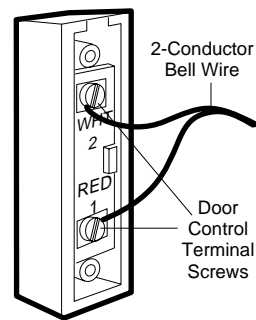

## Installation Step 7

### Install the Light and the Lens

#### Install the light:

- Install a 75 watt maximum light bulb in the socket. The light will turn ON and remain lit for approximately 4-1/2 minutes when power is connected. Then the light will turn OFF.
- If the bulbs burn out prematurely due to vibration, replace with a standard-neck "Garage Door Opener" bulb.

#### Install the lens:

(All Models except 1240R)

- Locate and loosen (approximately 1/8") the two screws near top of opener front panel. Position lens against panel with slotted tabs directly below screws. Slide lens up to seat tabs behind screws. Snap bottom tabs of lens into panel slots. Retighten top panel screws to secure lens.

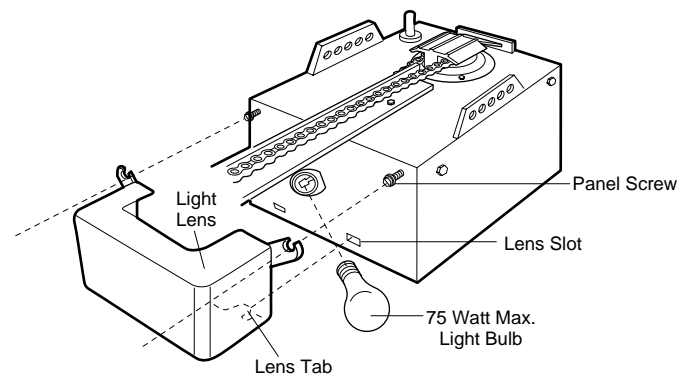

## Installation Step 8

### Attach the Manual Release Rope and Handle

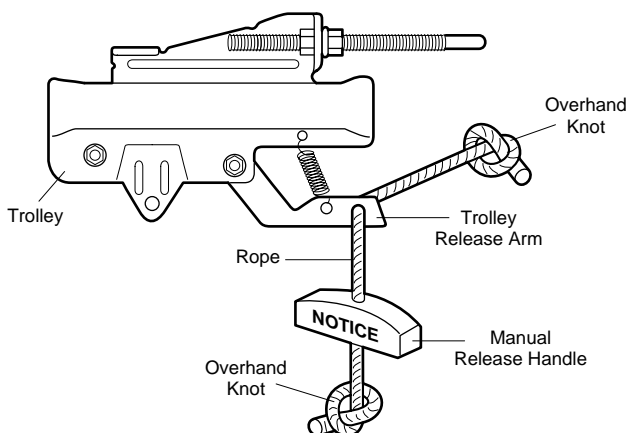

## WARNING

Do not use the red handle to pull the door open or closed. *The rope knot could become untied and you could fall.* Use the manual release only to disengage the trolley and, if possible, only when the door is closed.

Garage doors are heavy. If the door is open when the handle is pulled, the door could close inadvertently if it is not properly balanced. Serious injury may result to persons under the door. Make sure the doorway is clear of persons and obstructions before pulling handle when door is open.

- Thread one end of the rope through the hole in the top of the red handle so "NOTICE" reads right side up as shown. Secure with an overhand knot at least 1" from the end of the rope to prevent slipping.
- Thread the other end of the rope through the hole in the release arm of the outer trolley.
- Adjust rope length so the handle is 6 feet above the floor. Secure with an overhand knot.

If it is necessary to cut the rope, heat seal the cut end with a match or lighter to prevent unraveling.

## Installation Step 9

### Electrical Requirements

To reduce the risk of electric shock, your garage door opener has a grounding type plug with a third grounding pin. This plug will *only* fit into a grounding type outlet.

If the plug doesn't fit into the outlet you have, contact a qualified electrician to install the proper outlet.

**To avoid installation difficulties, do not run the opener at this time.**



## WARNING

To prevent electrocution or fire, installation and wiring must be in compliance with local electrical and building codes.

**Do NOT use an extension cord, 2-wire adapter, or change the plug in any way to make it fit your outlet.**

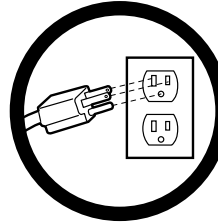

Right

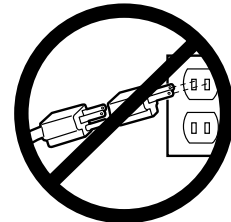

Wrong

If permanent wiring is required by your local code, refer to the following procedure:



## WARNING

To prevent electrocution, remove power from the garage door opener *and* from the circuit you plan to use for the permanent connection.

To make a permanent connection through the 7/8" diameter hole in the top of the opener (according to local code):

- Remove the opener cover screws and set the cover aside.
- Remove the attached 3-prong cord.
- Connect the black (line) wire to the screw on the brass terminal; the white (neutral) wire to the screw on the silver terminal; and the ground wire to the green ground screw. **The opener must be grounded.**
- Reinstall the cover.

**To avoid installation difficulties, do not run the opener at this time.**

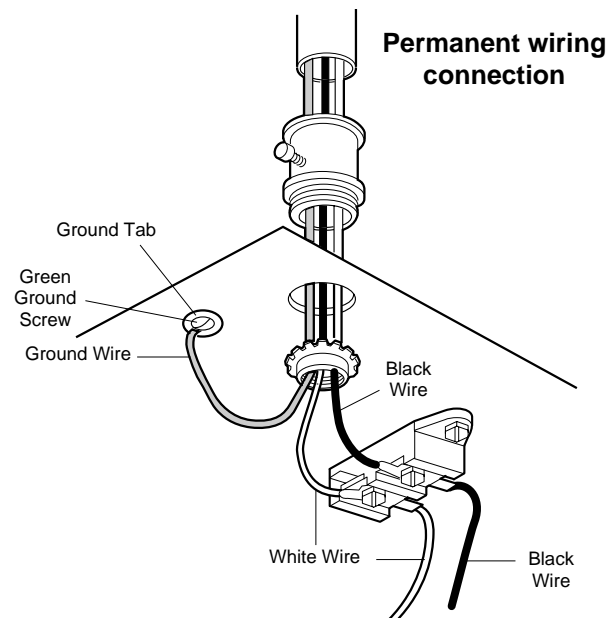

# The Protector System®

## IMPORTANT INFORMATION ABOUT THE SAFETY REVERSING SENSOR

The safety reversing sensor *must* be connected and aligned correctly before the garage door opener will move in the down direction. This is a required safety device and cannot be disabled.

When properly connected and aligned, the safety reversing sensor will detect an obstacle in the path of its electronic beam. The sending eye (with an orange indicator light) transmits an invisible light beam to the receiving eye (with a green indicator light). If an obstruction breaks the light beam while the door is closing, the door will stop and reverse to full open position, and the door control will flash for 5 seconds.

The units must be installed inside the garage so that the sending and receiving eyes face each other across the door, between 4 – 6" above the floor. Either can be installed on the left or right of the door as long as the sun never shines directly into the receiving eye lens.

The mounting brackets are designed to clip onto the track of sectional garage doors without additional hardware.



## WARNING

*Without a properly working safety reversing sensor, persons (particularly children) could be injured or killed by a closing garage door. Read and follow all instructions.*

**To protect small children, install the safety reversing sensor so that the beam will be no higher than 4"-6" above the garage floor.**

**Disconnect power to the garage door opener before installing the safety reversing sensor.**

If it is necessary to mount the units on the wall, the brackets must be securely fastened to a solid surface such as the wall framing. Extension brackets (see accessories) are available if needed. If installing in masonry construction, add a piece of wood at each location to avoid drilling extra holes in masonry if repositioning is necessary.

The invisible light beam path must be unobstructed. No part of the garage door (or door tracks, springs, hinges, rollers or other hardware) may interrupt the beam while the door is closing.

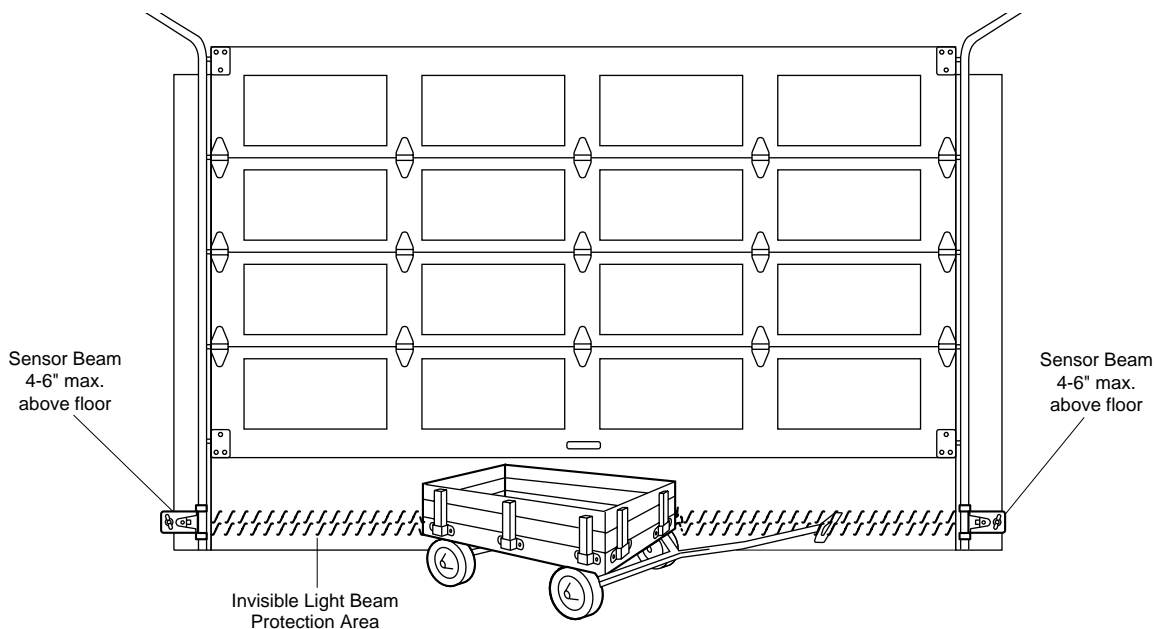

**Figure 1: Facing the door from inside the garage**

## Installation Step 10

### Install the Safety Reversing Sensor (Receiving and Sending Eyes)

#### INSTALLING THE BRACKETS

Be sure power to the opener is disconnected. Install and align the brackets so the sensors will face each other across the garage door, with the beam from 4 – 6" above the floor.

They may be installed in one of three ways, as follows.

#### Garage door track installation (preferred):

- Slip the curved arms over the rounded edge of each door track, with the curved arms facing the door. Snap into place against the side of the track. It should lie flush, with the lip hugging the back edge of the track, as shown in Figure 2.

If your door track will not support the bracket securely, wall installation is recommended.

#### Wall installation:

- Place the bracket against the wall with curved arms facing the door. Be sure there is enough clearance for the sensor beam to be unobstructed.
- If additional depth is needed, an extension bracket (see Accessories) or wood blocks can be used.
- Use bracket mounting holes as a template to locate and drill (2) 3/16" diameter pilot holes on the wall at each side of the door, from 4–6" above the floor.
- Attach brackets to wall with lag screws (not provided).
- If using extension brackets or wood blocks, adjust right and left assemblies to the same distance out from the mounting surface. Make sure all door hardware obstructions are cleared.

#### Floor installation:

- Use wood blocks or extension brackets (see Accessories) to elevate sensor brackets so the lenses will be 4-6" above the floor.
- Carefully measure and place right and left assemblies at the same distance out from the wall. Be sure all door hardware obstructions are cleared.
- Fasten to the floor with concrete anchors as shown.

Figure 2 DOOR TRACK MOUNT (Right Side)

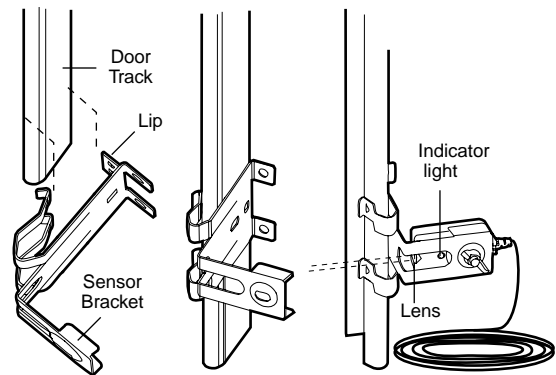

Figure 3 WALL MOUNT (Right Side)

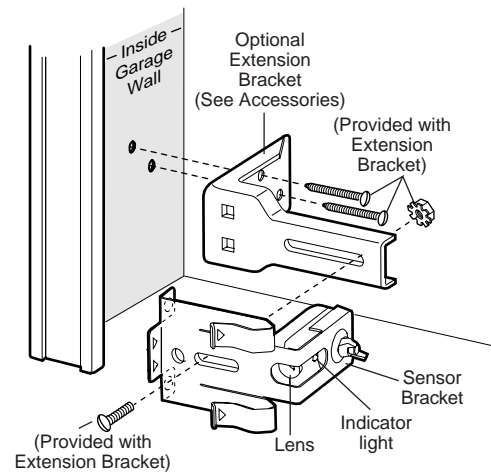
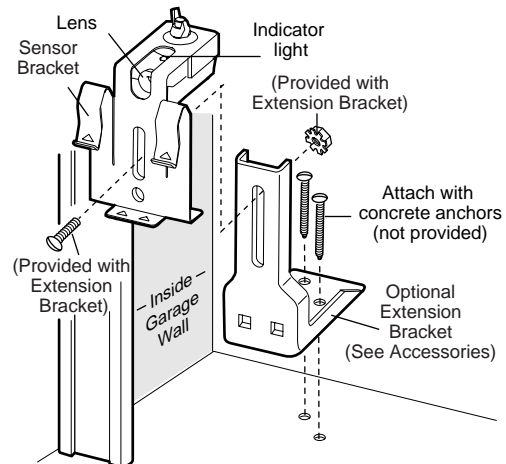
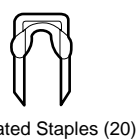
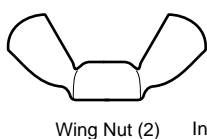
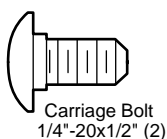

Figure 4 FLOOR MOUNT (Right Side)



#### Hardware Shown Actual Size



## MOUNTING AND WIRING THE SAFETY SENSORS

- Slide a 1/4"-20x1/2" carriage bolt head into the slot on each sensor. Use wing nuts to fasten sensors to brackets, with lenses pointing toward each other across the door. Be sure the lens is not obstructed by a bracket extension. See Figure 5.
- Finger tighten the wing nuts.
- Run the wires from both sensors to the opener. Use insulated staples to secure wire to wall and ceiling.
- Strip 1/4" of insulation from each set of wires. Separate white and white/black wires sufficiently to connect to the opener terminal screws: white to 2 and white/black to 3.

## ALIGNING THE SAFETY SENSORS

- Plug in the opener. The indicator lights in both the sending and receiving eyes will *glow steadily* if wiring connections and alignment are correct.

The *sending eye* orange indicator light will glow regardless of alignment or obstruction. If the green indicator light in the *receiving eye* is off, dim, or flickering (and the invisible light beam path is not obstructed), alignment is required.

- Loosen the *sending eye* wing nut and readjust, aiming directly at the receiving eye. Lock in place.
- Loosen the *receiving eye* wing nut and adjust sensor until it receives the sender's beam. When the green indicator light *glows steadily*, tighten the wing nut.

Figure 5

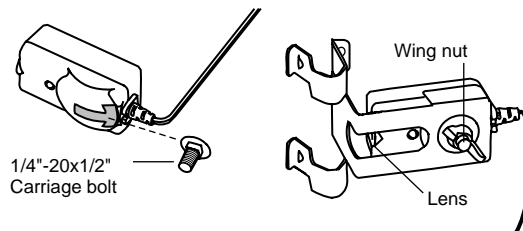

## TROUBLESHOOTING THE SAFETY SENSORS

1. If the *sending eye* indicator light does not *glow steadily* after installation, check for:
  - Electric power to the opener.
  - A short in the white or white/black wires. These can occur at staples, or at screw terminal connections.
  - Incorrect wiring between sensors and opener.
  - A broken wire.
2. If the sending eye indicator light *glows steadily* but the receiving eye indicator light doesn't:
  - Check alignment.
  - Check for an open wire to the receiving eye.
3. If the receiving eye indicator light is dim, realign either sensor.

**NOTE:** When the invisible beam path is obstructed or misaligned while the door is closing, the door will reverse. If the door is already open, it will not close. The door control will blink 10 times. See page 21.

Figure 6 Wiring the Safety Sensors

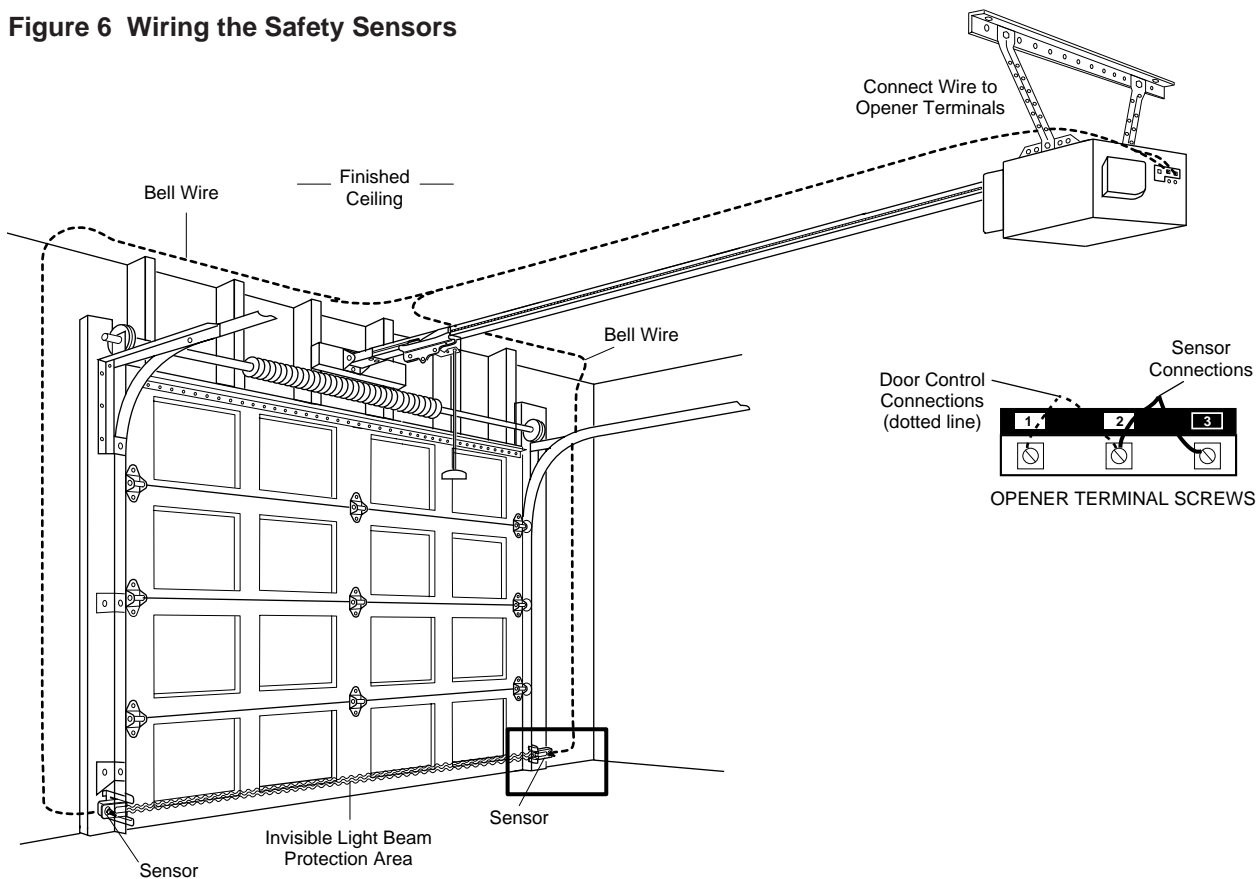

## Installation Step 11

### Fasten Door Bracket

Follow instructions which apply to your door type as illustrated below or on page 25.



## CAUTION

To prevent damage to steel, aluminum, fiberglass or glass panel doors, always reinforce the inside of the door both vertically and horizontally with angle iron.

A horizontal brace should be long enough to be secured to 2 vertical supports. A vertical brace should cover the height of the top panel.

The illustration shows one piece of angle iron as the horizontal brace. For the vertical brace, 2 pieces of angle iron are used to create a "U"-shaped support. The best solution is to check with your garage door manufacturer for an opener installation door reinforcement kit.

### SECTIONAL Door Installation Procedure

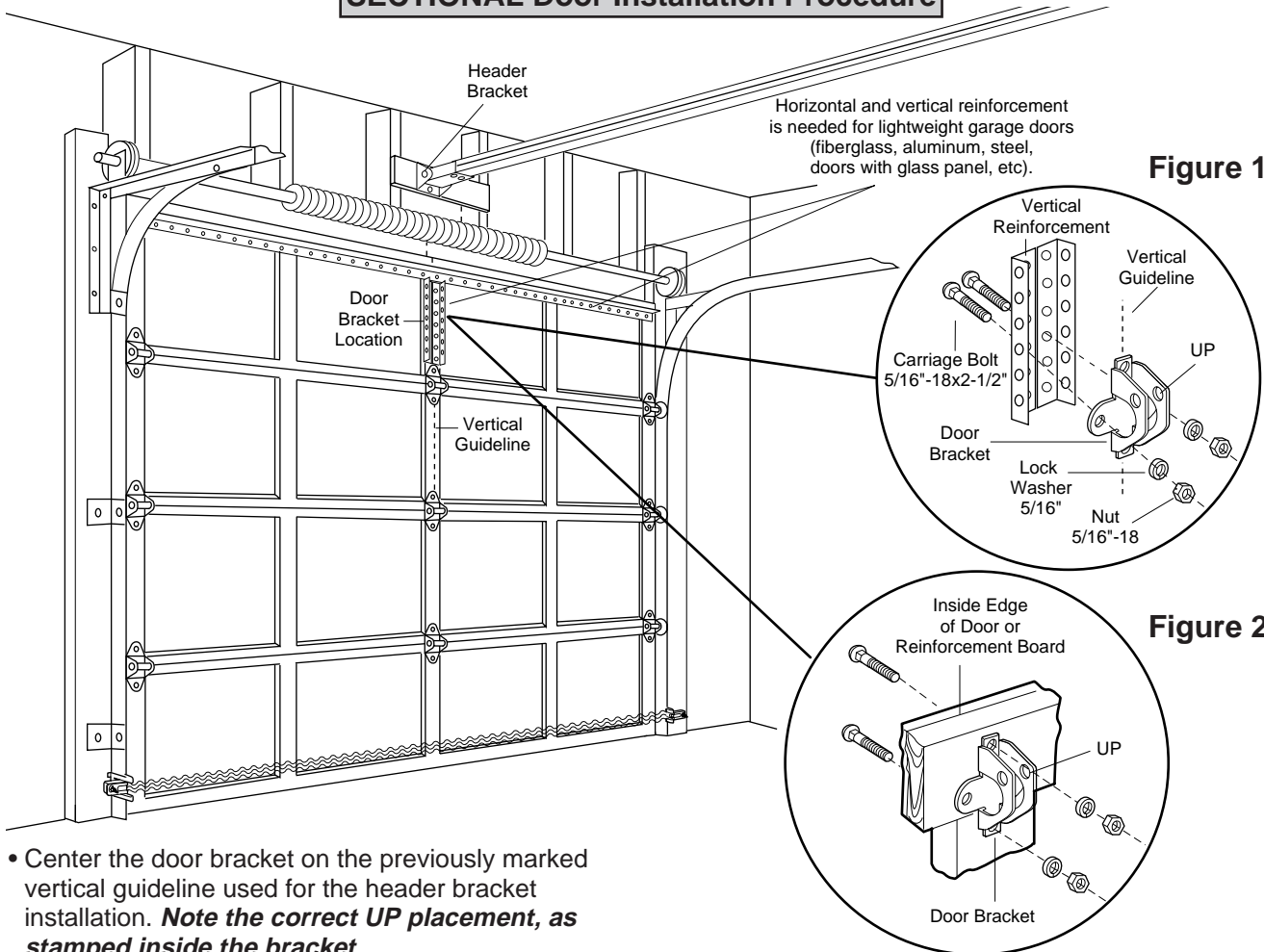

- Center the door bracket on the previously marked vertical guideline used for the header bracket installation. **Note the correct UP placement, as stamped inside the bracket.**
- Position the bracket on the face of the door within the following limits:
  - A) The top edge of the bracket 2"-4" below the top edge of the door.
  - B) The top edge of the bracket directly below any structural support across the top of the door.
- Mark and drill 5/16" left and right fastening holes. Secure the bracket as shown in Figure 1 if there is vertical reinforcement.

If your installation doesn't require vertical reinforcement but does need top and bottom fastening holes for the door bracket, fasten as shown in Figure 2.

### Hardware Shown Actual Size

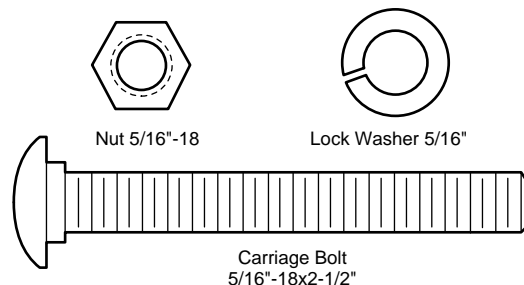

## All ONE-PIECE Door Installation Procedure

Please read and comply with the warnings and reinforcement instructions on page 24. They apply to one-piece doors also.

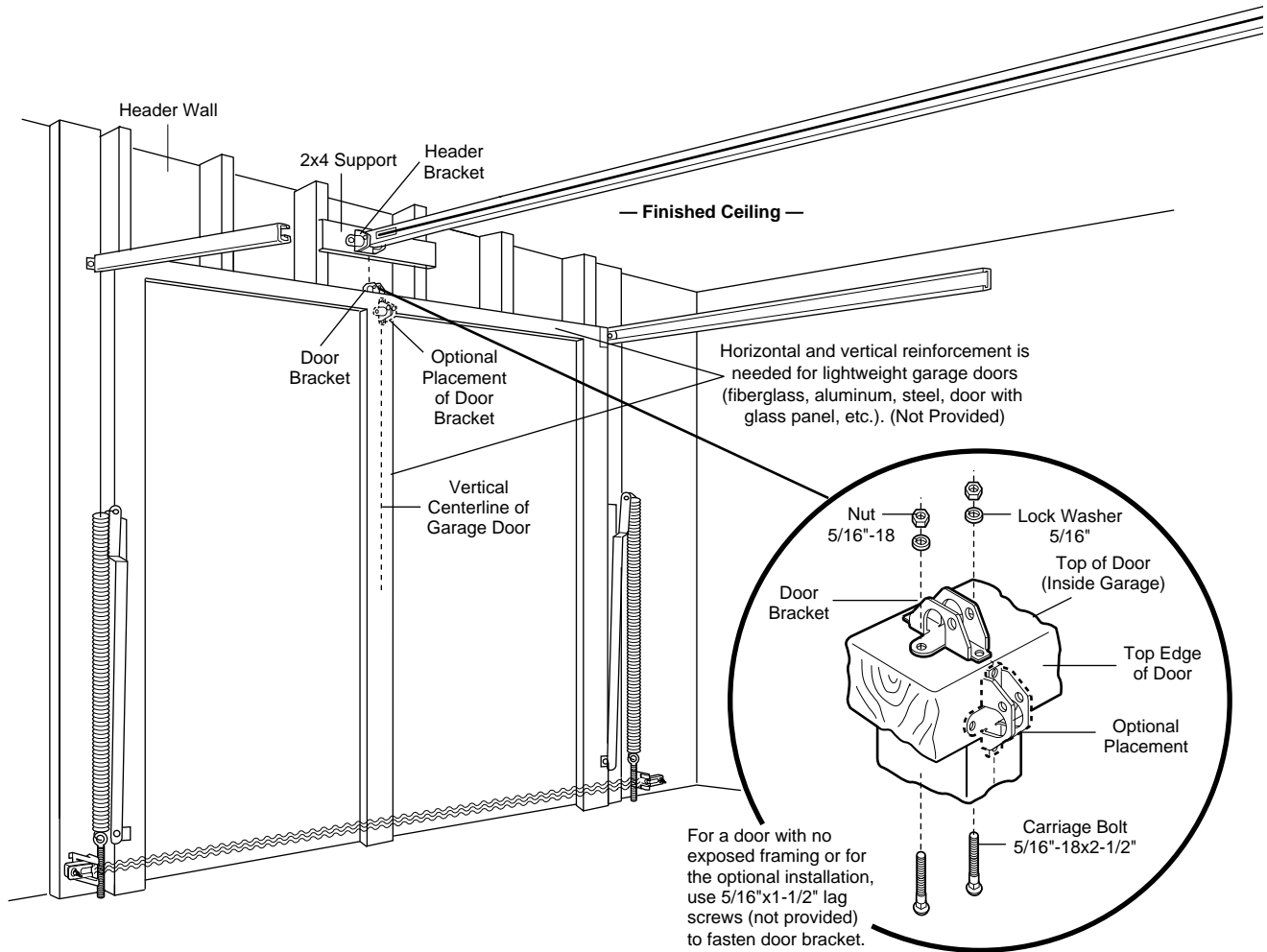

- Center the bracket on the top of the door, in line with the header bracket as shown. Mark holes.
- Drill 5/16" pilot holes and fasten the door bracket with hardware supplied.

If the door has no exposed framing, drill 3/16" pilot holes and fasten the bracket with 5/16"x1-1/2" lag screws (not supplied) to the top of the door.

**The door bracket may be installed on the top edge of the door if required for your installation. (Refer to the dotted line optional placement drawing.) Drill 3/16" pilot holes and substitute 5/16"x1-1/2" lag screws (not supplied) to fasten the bracket to the door.**

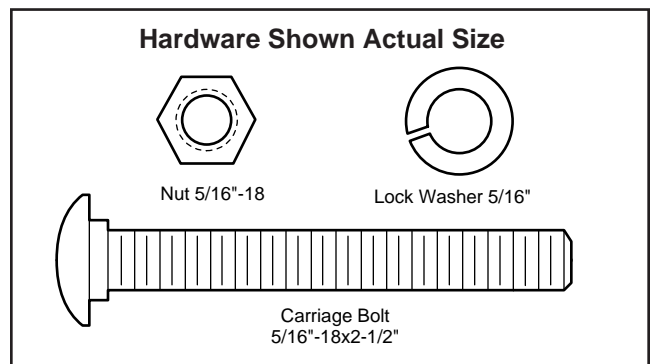

# Installation Step 12

## Connect Door Arm to Trolley

Follow instructions which apply to your door type as illustrated below and on page 27.

### SECTIONAL Doors Only

Make sure garage door is fully closed. Pull the manual release handle to disconnect the outer trolley from the inner trolley. Slide the outer trolley back (away from the door) about 2" as shown in Figures 1-3.

**Figure 1:**

- Fasten straight door arm section to outer trolley with the 5/16"x1" clevis pin. Secure the connection with a ring fastener.
- Fasten curved section to the door bracket in the same way, using the 5/16"x1-1/4" clevis pin.

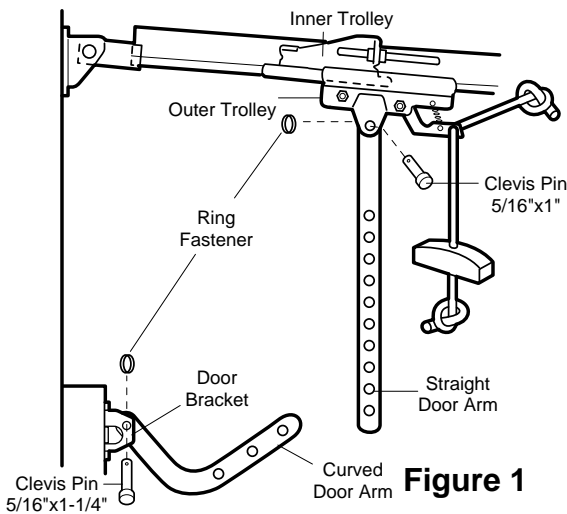

**Figure 1**

**Figure 2:**

- Bring arm sections together. Find two pairs of holes that line up and join sections. Select holes as far apart as possible to increase door arm rigidity.

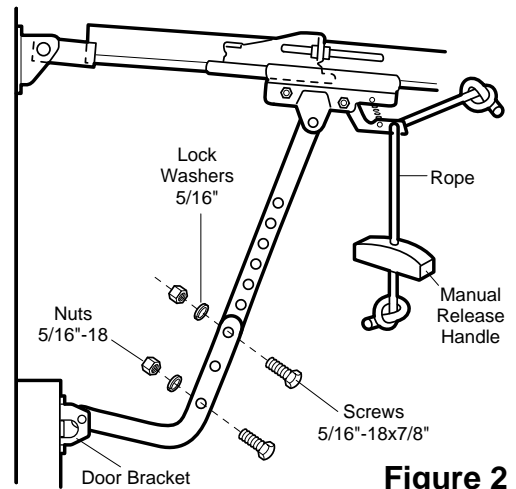
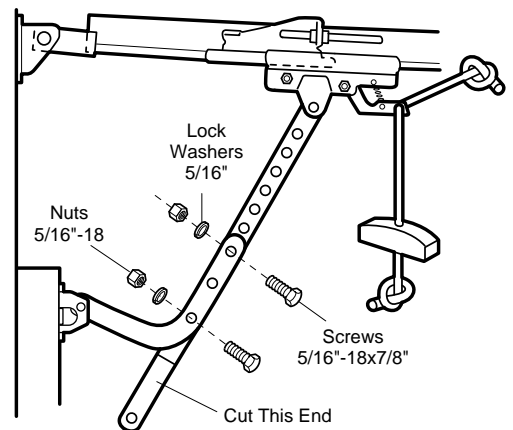

**Figure 2**

### Hole Alignment Alternative

**Figure 3:**

- If holes in curved arm are *above* holes in straight arm, disconnect straight arm. Cut about 6" from the solid end. Reconnect to trolley with *cut end down* as shown.
- Bring arm sections together.
- Find two pairs of holes that line up and join with screws, lock washers and nuts.



**Figure 3**

#### Hardware Shown Actual Size

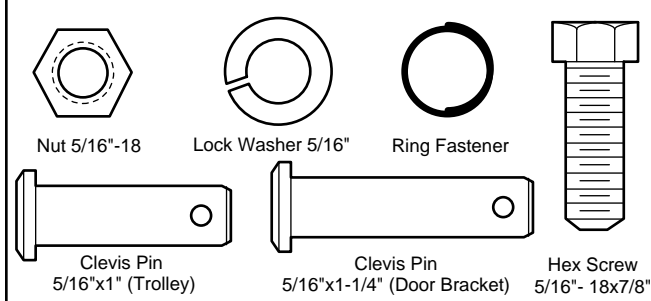

Proceed to Adjustment Step 1, page 28. Trolley will re-engage automatically when the opener is operated.

## All ONE-PIECE Doors

### Assemble the Door Arm:

- Fasten the straight and curved door arm sections together to the longest possible length (with a 2 or 3 hole overlap).
- With the door closed, connect the straight door arm section to the door bracket with the 5/16"x1-1/4" clevis pin.
- Secure with a ring fastener.

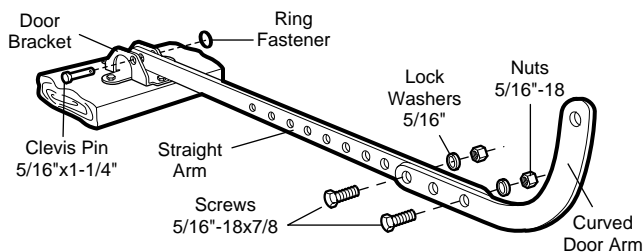

On one-piece doors, before connecting the door arm to the trolley the travel limits must be adjusted. Limit adjustment screws are located on the left side panel as shown on page 28. Follow adjustment procedures below.

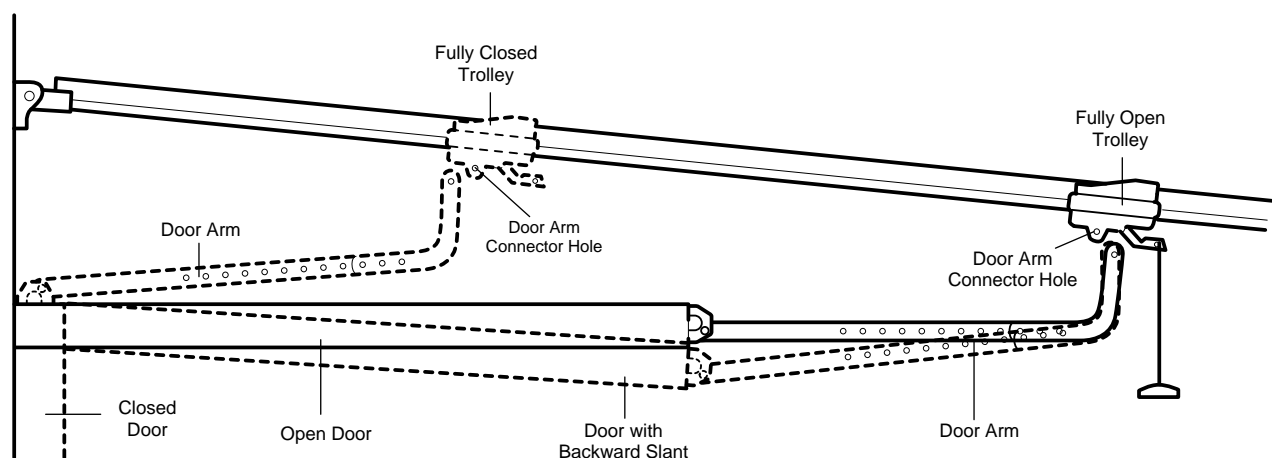

### Adjustment Procedures for One-Piece Doors

#### Open Door Adjustment: Decrease UP limit

- Turn the UP limit adjustment screw counter-clockwise 5-1/2 turns.
- Press the Door Control button. The trolley will travel to the fully open position.
- Manually raise the door to the open position (parallel to the floor), and lift the door arm to the trolley. The arm should touch the trolley just in back of the door arm connector hole. Refer to the fully open trolley/door arm positions in the illustration. If the arm does not extend far enough, adjust the limit further. One full turn equals 2" of trolley travel.

#### Closed Door Adjustment: Decrease DOWN limit

- Turn the DOWN limit adjustment screw clockwise 5 complete turns.
- Press the Door Control button. The trolley will travel to the fully closed position.
- Manually close the door and lift the door arm to the trolley. The arm should touch the trolley just ahead of the door arm connector hole. Refer to the fully closed trolley/door arm positions in the illustration. If the arm is behind the connector hole, adjust the limit further. One full turn equals 2" of trolley travel.

### Connect the door arm to the trolley.

- Close the door and join the curved arm to the connector hole in the trolley with the remaining clevis pin. **It may be necessary to lift the door slightly to make the connection.**
- Secure with a ring fastener.
- Run the opener through a complete travel cycle. If the door has a slight "backward" slant in full open position as shown in the illustration, decrease the UP limit until the door is parallel to the floor.

## Adjustment Step 1

### Adjust the UP and DOWN Limits

Do not make any limit adjustments until the safety reversing sensors are completely installed.

Limit adjustment settings regulate the points at which the door will *stop* when moving up or down.

The door will *stop* in the *up* direction if anything interferes with door travel. The door will *reverse* in the *down* direction if anything interferes with the door travel (including binding or unbalanced doors).

To operate the opener, press the Door Control button. Run the opener through a complete travel cycle.

- Does the door open and close completely?
- Does the door stay closed and not reverse unintentionally when fully closed?

If your door passes both of these tests, no limit adjustments are necessary unless the reversing test fails (see page 30).

Adjustment procedures are outlined below. **Run the opener through a complete travel cycle after each adjustment.**

*Repeated operation of the opener during adjustment procedures may cause the motor to overheat and shut off. Simply wait 15 minutes and try again.*

Read the procedures carefully before continuing on to Adjustment Step 2. Use a screwdriver to make limit adjustments.

### How and When to Adjust the Limits

- **If the door does not *open completely*, but opens at least five feet:**

Increase *up* travel. Turn the UP limit adjustment screw clockwise. One turn equals 2" of travel.

**NOTE:** To prevent the trolley from hitting the cover protection bolt, keep a minimum distance of 2-4" between the trolley and the bolt.

- **If door does not open at least 5 feet:**

Adjust the UP (open) force as explained in Adjustment Step 2.

- **If the door does not *close completely*:**

Increase *down* travel. Turn the DOWN limit adjustment screw counterclockwise. One turn equals 2" of travel.

If the door still won't close completely and the trolley bumps into the pulley bracket (see page 4 or 5), try lengthening the door arm (see page 26).



## WARNING

Improper adjustment of the travel limits will interfere with the proper operation of the safety reverse system. *The door might not reverse properly when required and could seriously injure or kill someone under it.* Test the safety reverse system following all adjustments to the travel limits. See page 30.

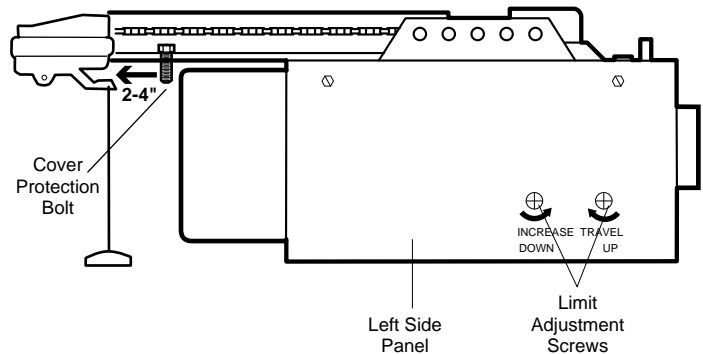

Limit Adjustment Label

If you have adjusted the door arm to the maximum length and the door still will not close completely, lower the header bracket. See Installation Step 1, pages 12 and 13.

- **If the opener *reverses* in fully closed position:**

Decrease *down* travel. Turn the DOWN limit adjustment screw clockwise. One turn equals 2" of travel.

- **If the door *reverses* when closing and there is no visible interference to travel cycle:**

If the opener lights are flashing, the Safety Reversing Sensors are either not installed, misaligned, or obstructed. See Troubleshooting, page 23.

Test the door for binding: Pull the manual release handle. Manually open and close the door. If the door is binding, call for garage door service. If the door is not binding or unbalanced, adjust the DOWN (close) force. See Adjustment Step 2.

## Adjustment Step 2

### Adjust the Force

Force adjustment controls are located on the back panel of the opener. Force adjustment settings regulate the amount of power required to open and close the door.

The door will *stop* in the *up* direction if anything interferes with its travel. The door will *reverse* in the *down* direction if anything interferes with its travel (including binding or unbalanced doors).

If the forces are set too light, door travel may be interrupted by *nuisance reversals* in the *down* direction and *stops* in the *up* direction. Weather conditions can affect the door movement, so occasional adjustment may be needed.

The maximum force adjustment range is 260 degrees, about 3/4 of a complete turn. Do not force controls beyond that point. Turn force adjustment controls with a screwdriver.

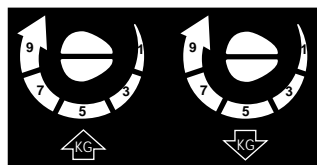

Force Adjustment Label

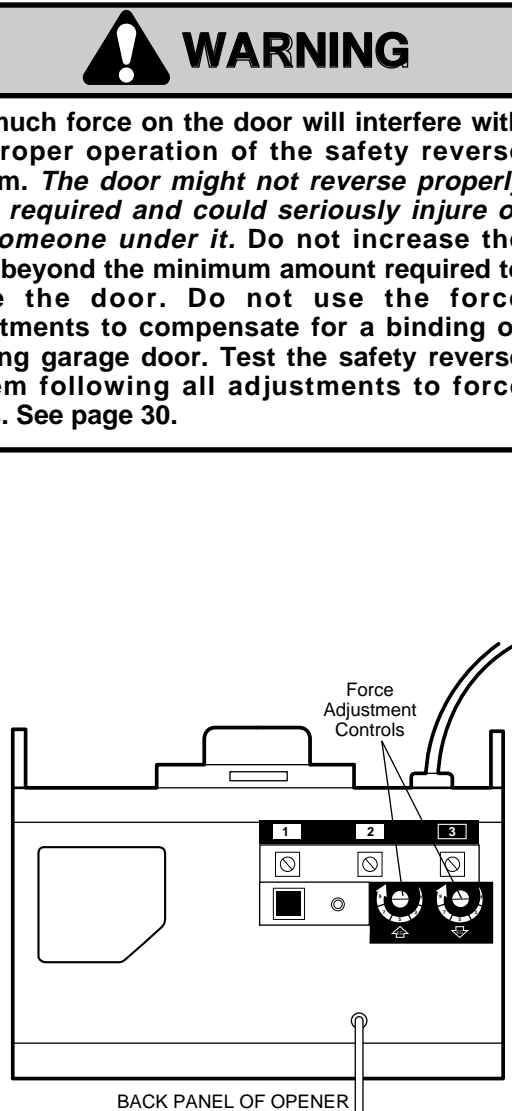

BACK PANEL OF OPENER



## WARNING

Too much force on the door will interfere with the proper operation of the safety reverse system. *The door might not reverse properly when required and could seriously injure or kill someone under it.* Do not increase the force beyond the minimum amount required to close the door. Do not use the force adjustments to compensate for a binding or sticking garage door. Test the safety reverse system following all adjustments to force levels. See page 30.

## How and When to Adjust the Forces

### Test the DOWN (close) force:

Grasp the door bottom when the door is about halfway through DOWN (close) travel. The door should reverse. **Reversal halfway through down travel does not guarantee reversal on a two-inch obstruction. See page 30.** If the door is hard to hold or doesn't reverse, decrease the DOWN (close) force by turning the control counterclockwise.

Make 10 degree turn adjustments until the door reverses normally. After each adjustment, run the opener through a complete cycle.

### Test the UP (open) force:

Grasp the door bottom when the door is about halfway through UP (open) travel. The door should stop. If the door is hard to hold or doesn't stop, decrease UP (open) force by turning the control counterclockwise.

Make 10 degree turn adjustments until the door stops easily. After each adjustment, run the opener through a complete travel cycle.

### If the door doesn't open at least 5 feet:

Increase UP (Open) force by turning the control clockwise. Make 10 degree turn adjustments until door opens completely. Re-adjust the UP limit if necessary. After each adjustment, run the opener through a complete travel cycle.

### If the door reverses during the down (close) cycle and the opener lights aren't flashing:

Increase DOWN (close) force by turning the control clockwise. Make 10 degree turn adjustments until the door completes a close cycle. After each adjustment, run the opener through a complete travel cycle. **Do not increase the force beyond the minimum amount required to close the door.**

## Adjustment Step 3

### Test The Protector System®

- Press the remote control push button to open the door.
- Place the opener carton in the path of the door.
- Press the remote control push button to close the door. *The door will not move more than an inch, and the opener light will flash.*

**Professional service is required if the opener closes the door when the safety reversing sensor is obstructed.**

The garage door opener will not close from a remote if the indicator light in either sensor is off, alerting you to the fact that the sensor is misaligned or obstructed.

The garage door can be closed by pressing and holding the door control button until down travel is completed.



## WARNING

**Without a properly working safety reversing sensor, persons (particularly children) could be seriously injured or killed if trapped by a closing garage door. Repeat this test once a month.**

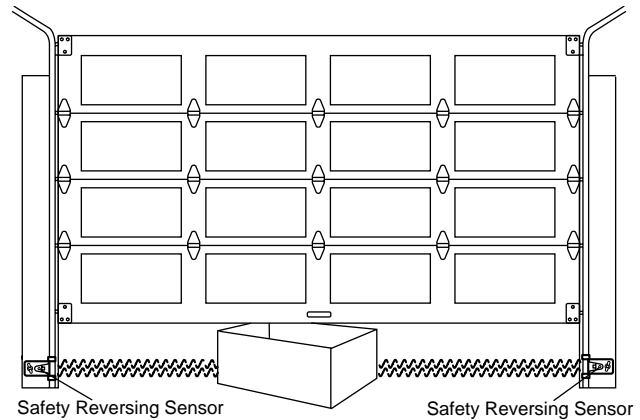

## Adjustment Step 4

### Test the Safety Reverse System

#### Test:

- Place a one-inch board (or a 2x4 laid flat) on the floor, centered under the garage door.
- Operate the door in the down direction. **The door must reverse on striking the obstruction.**

#### Adjustment:

If the door *stops* on the obstruction, it is not traveling far enough in the down direction.

- Increase the DOWN limit by turning the DOWN limit adjustment screw counterclockwise 1/4 turn.
- Repeat the test.

**On a sectional door, make sure limit adjustments do not force the door arm beyond a straight up and down position. See the illustration on page 26.**

- When the door reverses on the one-inch object (or 2x4 laid flat), remove the obstruction and run the opener through 3 or 4 complete travel cycles to test adjustment.

If the door will not reverse after repeated adjustment attempts, call for professional garage door service.



## WARNING

**Failure to test and adjust the safety reverse system may result in serious injury or death to persons trapped by a closing garage door. Repeat this test once a month and adjust as needed.**

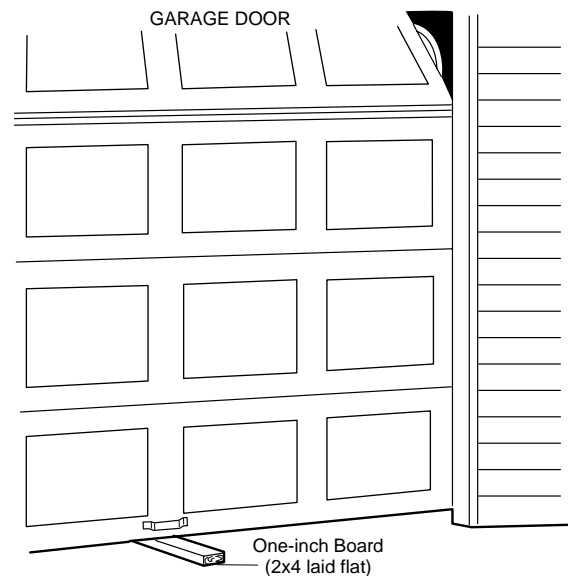

### Important safety check:

#### Repeat Adjustment Steps 1, 2 and 4 after:

- Each adjustment of door arm length, force controls or limit controls.
- Any repair to or adjustment of the garage door (including springs and hardware).
- Any repair to or buckling of the garage floor.
- Any repair to or adjustment of the opener.

# IMPORTANT SAFETY INSTRUCTIONS



**WARNING**



**WARNING**

## To reduce the risk of severe injury or death to persons:

1. READ AND FOLLOW ALL INSTRUCTIONS.
2. Do not permit children either to operate or to play with the opener. Keep remote control in a location inaccessible to children.
3. Operate opener only when the door is in full view and free from any obstruction. Keep the door in sight until it is completely closed. **NO ONE SHOULD CROSS THE PATH OF THE MOVING DOOR.**
4. Check safety reversal system monthly. See page 30. The garage door **MUST** reverse on contact with a one-inch object (or a 2x4 board laid flat) placed on the floor. If an adjustment is made to either the force or the limit of travel, both adjustments may be needed and the safety reversal system must be checked. *Failure to properly adjust the opener may result in severe injury or death.*
5. If possible, use the manual release only when the door is in a closed position. Caution should be taken whenever the disconnect cord is actuated with the door open. *Weak or broken springs may cause the door to fall rapidly, causing injury or death to persons.*
6. **KEEP GARAGE DOORS PROPERLY BALANCED.** See page 3. *An improperly balanced door may not reverse when required and could result in severe injury or death.* Repairs to cables, spring assemblies and other hardware must be made by a professional garage door person.
7. Disconnect the electric power from the garage door opener before making any repairs or removing the covers.
8. **SAVE THESE INSTRUCTIONS.**

## Care of Your Opener

### Limit and force adjustment controls

#### Limit Controls



Adjustment Label  
(Located on the left side panel)

#### Force Controls

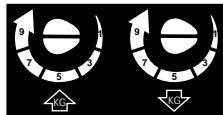

Adjustment Label  
(Located on the back panel)

Weather conditions may cause some minor changes in door operation requiring some re-adjustments, particularly during the first year of operation. Pages 28 and 29 refer to the limit and force adjustments. Only a screwdriver is required. Follow the instructions carefully.

**Repeat the safety reverse test (page 30) after any adjustment of limits or force.**

### MAINTENANCE SCHEDULE

#### *Once a Month*

**Manually operate door.** If it is unbalanced or binding, call for professional garage door service.

**Check to be sure door opens & closes fully.** Adjust limits and/or force if necessary. (See pages 28 and 29.)

**Repeat the safety reverse test.** Make any necessary adjustments (See page 30).

#### *Twice a Year*

**Check chain tension.** Disconnect trolley first. Adjust if necessary (See page 11).

#### *Once a Year*

**Oil door rollers, bearings and hinges.** The opener does not require additional lubrication. Do not grease the door tracks.



**WARNING**

Keep batteries away from small children. If swallowed, promptly notify doctor.

### The remote control transmitter

The opener must learn the code of any new remote control. Page 33 explains how to program your receiver and how to erase all codes if required. Self service of your receiver and remote control is not recommended. If service is needed, call the toll-free number listed on the back page.

### The remote control battery

The lithium battery should produce power for up to 5 years. To replace the battery, pry open case with visor clip or screwdriver, as shown. Insert battery *positive side up*.

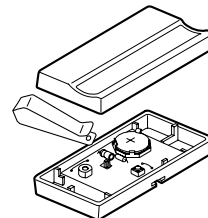

**Dispose of your old battery properly.**

# Operation of Your Opener

Activate the opener with any of the following devices:

- **The Remote Control Transmitter.** Hold push button down until the door starts to move.
- **The Door Control.** Hold button down until the door starts to move.
- **The Outside Keylock or Keyless Entry.** (See Accessories.)

**When the opener is activated with the Safety Reversing Sensor installed and correctly aligned:**

1. If open, the door will close. If closed, it will open.
2. If closing, the door will reverse.
3. If opening, the door will stop (allowing space for entry and exit of pets and for fresh air).
4. If the door has been stopped in a partially open position, it will close.
5. If obstructed while closing, the door will reverse.
6. If obstructed while opening, the door will stop.
7. The garage door will reverse in the closing cycle and the opener lights will blink for 5 seconds, when the invisible beam is broken. If fully open, the door will not close when the beam is broken. The sensor has no effect in the opening cycle.

If the sensor is not installed, or is not aligned correctly, the door won't close from any remote control transmitter. You can close the door with the Door Control, the Outside Keylock, or Keyless Entry, however, if you activate them *until down travel is complete*. If you release them too soon, the door will reverse.

**The Opener Light** will turn on under the following conditions: When the opener is initially plugged in; when the power is interrupted; when the opener is activated. It will turn off automatically after 4-1/2 minutes. Light will also turn on when someone walks through the open garage door. Bulb size is 75 watts maximum.

## Operation of the Door Control Button

Press to open or close the door.

Press again to *reverse* the door during the closing cycle or to *stop* the door while it's opening.



## WARNING

**Weak or broken springs could allow an open door to fall (either rapidly or unexpectedly), resulting in serious injury, death or property damage. If possible, use the manual release rope and handle *only* when the door is fully closed.**

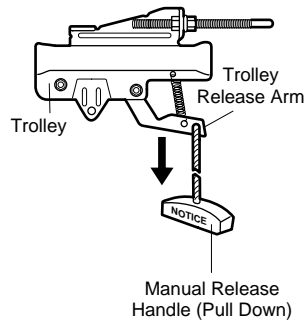

### Manual disconnect position

### To open the door manually:

The door should be fully closed if possible. Pull down on the red manual release handle and lift the door manually. To reconnect the door to the opener, press the Door Control button.

**The lockout feature** prevents the trolley from reconnecting automatically. Pull the red manual release handle down and back (toward the opener). The door can then be raised and lowered manually as often as necessary. To disengage the Lockout Feature, pull the manual handle straight down. The trolley will reconnect on the next UP or DOWN operation.

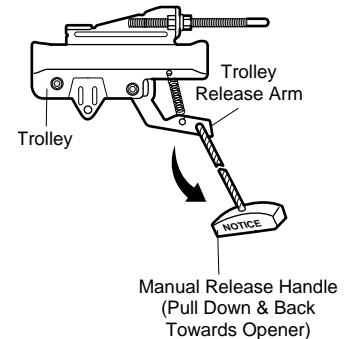

### Lockout position

# Receiver and Remote Control Programming



NOTICE: To comply with FCC rules, adjustment or modification of this receiver and/or transmitter are prohibited, except for changing the code setting or replacing the transmitter battery. THERE ARE NO OTHER USER SERVICEABLE PARTS.

Your garage door opener receiver and remote control transmitter have been set at the factory to a matching code. The door will open when you press the remote control push button. The code between the remote control and the receiver changes with each use, randomly accessing over 100 billion new codes.

Your SECURITY+ opener will operate with:

- several SECURITY+ remote controls (with yellow indicator lights) utilizing up to 8 functions.
- one Keyless Entry System (with SECURITY+ logo)

Below are instructions for programming your opener to match any additional remotes you may purchase. See available accessories on page 38.

## To Add A Remote

1. Press and *hold* the remote control push button. See Figure 1.
2. Then press and release the "Smart" (learn) button on the back panel of the opener in Figure 2. The indicator light on the panel will begin to blink and the opener light will *flash once*.
3. Release the remote push button.

Now the opener will operate when that remote control button is pressed. Test it by pressing the remote button to see that the door goes up and down.

**If you release the remote control push button before the opener light flashes, the opener will not accept the code.**

## To Erase All Remote Control Codes

- Press and hold the "Smart" button on the opener panel until the indicator light turns off (about 6 seconds). All transmitter codes are now erased. Then follow the steps above to re-program each remote control.

**Code programming instructions are also located on the opener panel.**



## WARNING

**Children operating or playing with a garage door opener can injure themselves or others. The garage door could close and cause serious injury or death. Do not allow children to operate the door control(s) or remote control transmitter(s).**

**A moving garage door could injure or kill someone under it. Activate the opener only when you can see the door clearly, it is free of obstructions, and is properly adjusted.**

Figure 1

### Model 91LM SECURITY+ Single-Function Remote Control

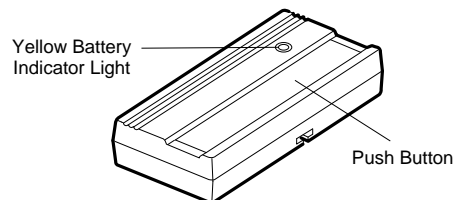
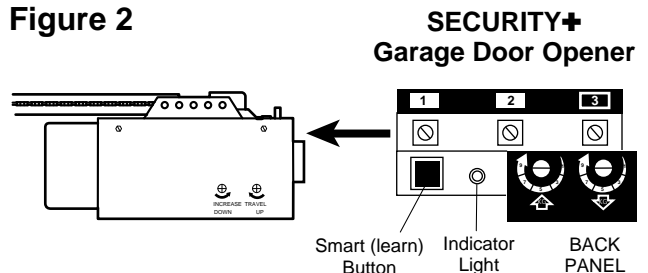

Figure 2



# Having a Problem?

Situation	Probable Cause & Solution
<b><i>The opener doesn't operate from either the door control or the remote control:</i></b>	<ol style="list-style-type: none"><li>1. Does the opener have electric power? Plug a lamp into the outlet. If it doesn't light, check the fuse box or the circuit breaker. (Some outlets are controlled by a wall switch.)</li><li>2. Have you disabled all door locks? Review installation instruction warnings on Page 11.</li><li>3. Is there a build-up of ice or snow under the door? The door may be frozen to the ground. Remove any restriction.</li><li>4. The garage door spring may be broken. Have it replaced.</li><li>5. Repeated operation may have tripped the overload protector in the motor. Wait 15 minutes. Try again.</li></ol>
<b><i>Opener operates from remote control, but not from door control:</i></b>	<ol style="list-style-type: none"><li>1. Is the door control push bar lit? If not, Remove the bell wire from the opener terminal screws. Short the red and white terminals by touching both terminals at the same time with a piece of wire. If the opener runs, check for a faulty wire connection at the door control, a short under the staples, or a broken wire.</li><li>2. Are the wiring connections correct? Review Step 6, page 18.</li></ol>
<b><i>The door operates from the door control, but not from the remote control:</i></b>	<ol style="list-style-type: none"><li>1. If your model has the Multi-Function "Lock feature", turn it <i>off</i>.</li><li>2. Your opener needs to re-learn a remote control code. Refer to instructions on the opener panel.</li><li>3. Program the receiver to match the remote control code.</li><li>4. Repeat the receiver programming procedure with all remote controls.</li></ol>
<b><i>The remote control has short range:</i></b>	<ol style="list-style-type: none"><li>1. Change the location of the remote control in your car.</li><li>2. Check to be sure the antenna on the side or back panel of the opener extends fully downward.</li><li>3. Some installations may have shorter range due to a metal door, foil backed insulation, or metal garage siding.</li></ol>
<b><i>Opener noise is disturbing in living quarters of home:</i></b>	If operational noise is a problem because of proximity of the opener to the living quarters, the Vibration Isolator Kit 41A3263 can be installed. This kit was designed to minimize vibration to the house and is easy to install.
<b><i>The garage door opens and closes by itself:</i></b>	<ol style="list-style-type: none"><li>1. Be sure that all remote control push buttons are off.</li><li>2. Remove the bell wire from the Door Control terminals and operate from the remote control only. If this solves the problem, the Door Control is faulty (replace), or there is an intermittent short on the wire between the Door Control and the opener.</li><li>3. Clear memory and reprogram all remote controls.</li></ol>
<b><i>The door doesn't open completely:</i></b>	<ol style="list-style-type: none"><li>1. Is something obstructing the door? Remove the obstruction or repair the door.</li><li>2. If the door has been working properly but now doesn't open all the way, increase the <i>up force</i>. See page 29.</li><li>3. If door opens at least 5 feet, the travel limits may need to be increased. One turn equals 2 inches of travel. See page 28.</li></ol> <p><b><i>Repeat the safety reverse test after the adjustment is complete.</i></b></p>
<b><i>The door stops but doesn't close completely:</i></b>	Review the travel limits adjustment procedures on page 28. <b><i>Repeat the safety reverse test after any adjustment of door arm length, close force or down limit.</i></b>

## Having a Problem? *(continued)*

Situation	Probable Cause & Solution
<b>The door opens but won't close:</b>	<ol style="list-style-type: none"><li>1. If the opener light blinks, check the safety reversing sensor. See page 23.</li><li>2. If the opener light does not blink and it is a new installation, check the down force. See Adjustment Step 2, page 29. For an existing installation, see below. <b>Repeat the safety reverse test after the adjustment is complete.</b></li></ol>
<b>The door reverses for no apparent reason and opener light doesn't blink:</b>	<ol style="list-style-type: none"><li>1. Is something obstructing the door? Pull the manual release handle. Operate the door manually. If it is unbalanced or binding, call for professional garage door service.</li><li>2. Clear any ice or snow from the garage floor area where the door closes.</li><li>3. Review the force adjustment procedures on page 29.</li><li>4. If door reverses in the <i>fully closed</i> position, decrease the travel limits (page 28). <b>Repeat safety reverse test after adjustments to force or travel limits. The need for occasional adjustment of the force and limit settings is normal. Weather conditions in particular can affect door travel.</b></li></ol>
<b>The door reverses for no apparent reason and opener light blinks for 5 seconds after reversing:</b>	Check the safety reversing sensor. Remove any obstruction or align the receiving eye. See page 23.
<b>The opener light:</b>	<p><b>. . . doesn't turn on:</b> Replace the light bulbs (75 watts maximum). Use a <i>standard neck</i> garage door opener bulb if regular bulb burns out.</p> <p><b>. . . doesn't turn off:</b> Is the Light feature <i>on</i>? Turn it <i>off</i>.</p>
<b>The opener strains or maximum force is needed to operate door:</b>	The door may be out of balance or the springs are broken. <b>Close the door</b> and use the manual release to disconnect the trolley. Open and close the door manually. A properly balanced door will stay in any point of travel while being supported entirely by its springs. If it does not, disconnect the opener and call a professional garage door serviceman. <b>Do not increase the force to operate the opener.</b>
<b>The opener motor hums briefly, then won't work:</b>	<ol style="list-style-type: none"><li>1. The garage door springs are broken. See above.</li><li>2. If the problem occurs on the first operation of the opener, door may be locked. <i>Disable the door lock</i>. If the chain was removed and reinstalled, the motor may be out of phase. Remove the chain; cycle the motor to the down position. Observe the drive sprocket. When it turns in a clockwise direction and stops in the down position, reinstall the chain. <b>Repeat the safety reverse test after the adjustment is complete.</b></li></ol>
<b>The opener won't operate due to power failure:</b>	<ol style="list-style-type: none"><li>1. Use the manual release to disconnect the trolley. The door can be opened and closed manually. When the power is restored, press the door control button and trolley will automatically reconnect (unless trolley is in lockout position.) See page 32.</li><li>2. The Outside Quick Release accessory (for use on garages with no service door) disconnects the trolley from outside the garage in case of power failure.</li></ol>
<b>The chain droops or sags:</b>	It is normal for the chain to droop slightly in the closed door position. Use the manual release to disconnect the trolley. If the chain returns to normal height when the trolley is disengaged and the door reverses on a one-inch board, no adjustments are needed (see page 11).

# Repair Parts

## Rail Assembly Parts

KEY NO.	PART NO.	DESCRIPTION
1	4A1008	Master link kit
2	41A4813	Chain pulley bracket
3	41A3489	Complete trolley assembly
4	183B99	One-piece T-rail
5	41D3484	Full chain assembly
6	83A4	Rail grease

## Installation Parts

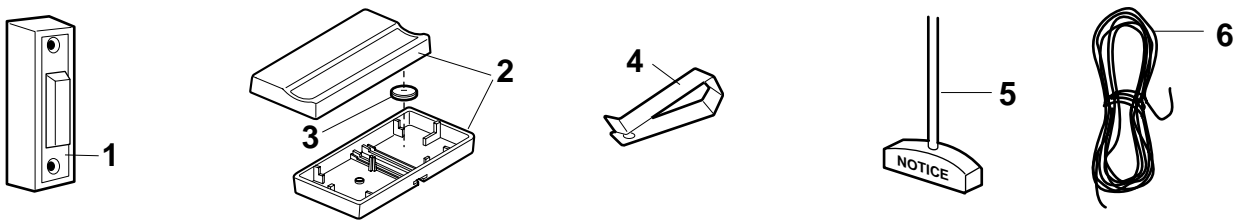

KEY NO.	PART NO.	DESCRIPTION
1	41A4166	Door control button
2	41A5056-1	Single-function remote control case (no circuit board)
3	10A20	3V2032 Lithium battery
4	29B137	Remote control visor clip
5	41A2828	Manual rope & handle assembly
6	217A238	2-Conductor bell wire - white & white/red
7	41A4353	Header bracket w/clevis pin & fastener
8	41A5047	Door bracket w/clevis pin & fastener
9	41A5034	Safety sensor kit (receiving and sending eyes) with 3' 2-conductor bell wire attached
10	178B34	Straight door arm section
11	178B35	Curved door arm section
12	12D584-1	Safety sensor brackets (2)
		<b>NOT SHOWN</b>
	41A2770-6	Installation hardware bag (includes hardware illustrated on page 7).
	114A2217	Owner's manual

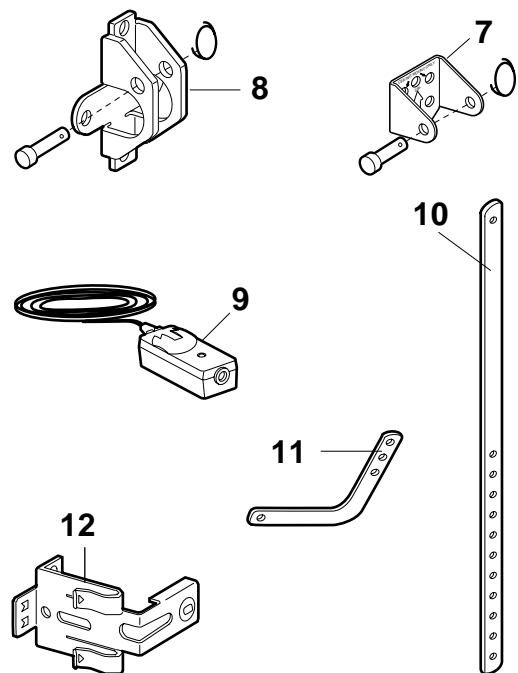

# Repair Parts

## Opener Assembly Parts

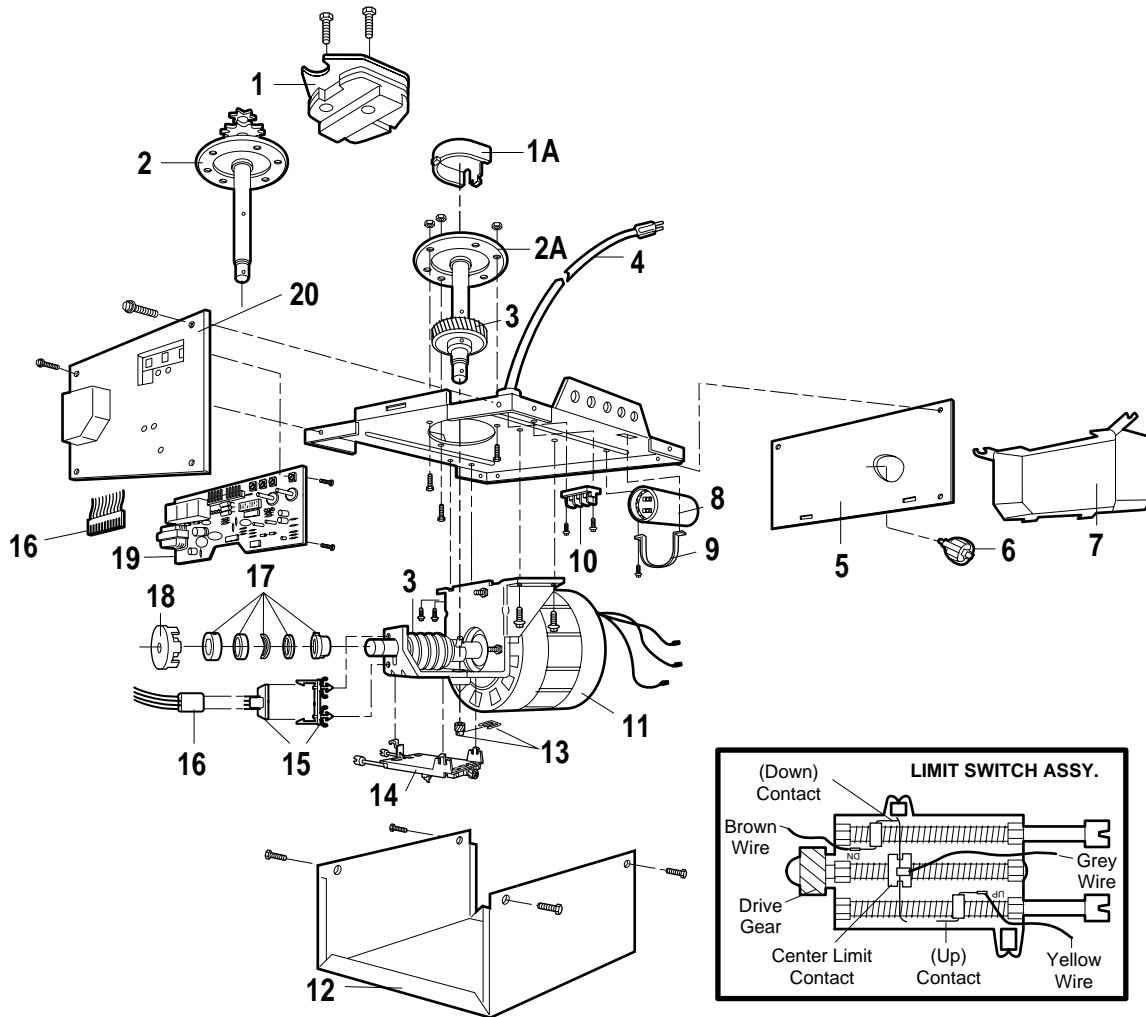

### KEY PART NO. NO.

### DESCRIPTION







1	41A4208	Chain spreader w/screws (1256R, 1246R)
1A	31D380	Sprocket cover (all other models)
2	41C4206A	Gear and sprocket assy. (1256R, 1246R)
2A	41C4220A	Gear and sprocket assy. (All other models) <b>Complete with:</b> Spring washer, Thrust washer, Retaining ring, Bearing plate, Roll pins (2), Drive gear and worm gear, Helical gear w/retainer and grease
3	41A2817	Drive/worm gear kit w/grease Roll pins (2)
4	41B4245	Line cord
5	143D100	End panel w/all labels
6	175B88	Light socket
7	108D36	Lens (All models except 1240R)
8	30B363	Capacitor - 1/2HP
	30B387	Capacitor - 1/3HP
	30B366	Capacitor - 1/4HP
9	12A373	Capacitor bracket
10	41A3150	Terminal block w/screws

### KEY PART NO. NO.

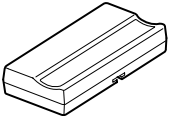
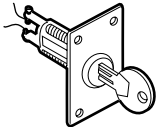
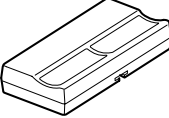
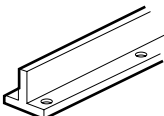
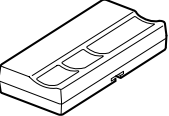
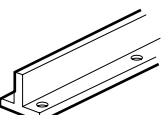
### DESCRIPTION

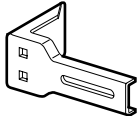
11	41D3058	Universal replacement motor & bracket assy. <b>Complete with:</b> Motor, worm, bracket, bearing assembly, RPM sensor.
12	41A3583-11	Cover (1256R, 1255R)
	41A3583-15	Cover (1246R, 1245R)
	41A3583-16	Cover (1240R)
13	41A2818	Helical gear & retainer w/grease
14	41D3452	Limit switch assembly
15	41C4398A	RPM sensor assembly
16	41C4246	Wire harness assy. w/plug
17	41A2826	Shaft bearing kit
18	41A2822A	Interrupter cup assy.
19	41A5021-1E	Receiver logic board assy. <b>Complete with:</b> Logic board, End panel w/all labels, Light socket
20	41A5014-3	End panel w/all labels <b>NOT SHOWN</b>
	41A2825	Opener assy. hardware kit (includes screws not designated by a number in illustration).

## Accessories Available For Your Opener

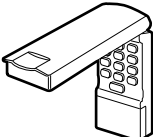
<p><b>Model 1702</b></p> 	<p><b>Outside Quick Release:</b>  <i>Required</i> for a garage with NO access door.</p>	<p><b>Model 971LM</b></p> 	<p><b>SECURITY+ Single-Function Remote Control:</b>          Includes visor clip.</p>
<p><b>Model 59</b></p> 	<p><b>Outside Keylock:</b>          Opens the garage door automatically from outside when remote control is not handy.</p>	<p><b>Model 972LM</b></p> 	<p><b>SECURITY+ 2-Channel Remote Control:</b>          Includes visor clip.</p>
<p><b>Model 1708LM</b></p> 	<p><b>8 foot Complete Rail:</b>          To allow an 8 foot door to open fully.</p>	<p><b>Model 973LM</b></p> 	<p><b>SECURITY+ 3-Channel Remote Control:</b>          Includes visor clip.</p>
<p><b>Model 1710LM</b></p> 	<p><b>10 foot Complete Rail:</b>          To allow a 10 foot door to open fully.</p>	<p><b>Model 974LM</b></p> 	<p><b>SECURITY+ 4-Channel Remote Control:</b>          Includes visor clip.</p>
<p><b>Model 97LM</b></p> 	<p><b>Extension Brackets:</b>          (Optional) For safety sensor installation onto the wall or floor.</p>	<p><b>Model 970LM</b></p> 	<p><b>SECURITY+ 3-Channel Mini Remote Control:</b>          With key ring and Velco fastening strip.</p>
<p><b>Model 58LM</b></p> 	<p><b>Multi-Function Door Control Panel:</b>          Provides a Lock Feature which prevents operation of garage door opener from portable remotes and a Light Feature for constant light.</p>	<p><b>Model 98LM</b></p> 	<p><b>Passive Infrared Control console:</b>          Multi-function door control with motion sensor that automatically turns opener lights on for 5 minutes when it detects a person entering the garage. Sensor can be easily deactivated when desired.</p>
<p><b>Model 976LM</b></p> 	<p><b>SECURITY+ Keyless Entry:</b>          Enables homeowner to operate garage door opener from outside by entering code on specially designed keyboard. Also can add a temporary pass code for visitors or service persons. This temporary code can be limited to a programmable number of hours or entries.</p>		

### To Add the Keyless Entry

**We recommend that you program your code before you install the Keyless Entry. You will not need assistance, and you can test the reception at the mounting location before installation.**

1. Choose a 4-digit code using numbers from 0 to 9 (a number can be used more than once, for example, 4, 0, 4, 1).
2. Press the four buttons for the code, then press and *hold* the Enter button. The indicator light on the door opener panel will blink.
3. Press and release the "Smart" (learn) button on the opener panel. After the opener light flashes, release the Enter button.

Test by pressing the the code, then press Enter. The door should begin to move.

**You may also program the Keyless Entry from the Multi-Function Door Control, as follows:**

1. *With the door closed*, enter the four digit code desired, then press and hold Enter.
2. Press and hold the light button on the door control.
3. Press and hold the door control push bar.
4. After the opener light flashes, release all buttons.

# Index

<b>Access Door/Outside Key Release Accessory</b> .....	4, 5
<b>Chain Tension</b> .....	4, 5, 11
<b>Electrical Safety Warnings</b> .....	2, 20, 31
<b>Garage Door</b>	
Testing for balance, binding and sticking .....	3, 28, 31
Determining high point of travel:	
Sectional Door .....	12
One-Piece Door .....	13
Disabling existing locks .....	3, 11
<b>Force Controls</b>	
Adjustment Procedures .....	29
Problems that might require Force adjustments .....	34, 35
Safety Warnings .....	29, 31
Door hardware .....	3, 9, 11, 12, 18, 31, 32
Maintenance Instruction Label .....	11, 28
Reinforcement requirements .....	4, 24
Removing of all ropes .....	3, 11
Possible door damage .....	16, 24
<b>Travel Limits</b>	
Adjustment Procedures .....	28
Problems that might require Limit adjustments .....	34, 35
Safety Warnings .....	28, 31
<b>Manual Release Rope &amp; Handle</b>	
Lockout Feature .....	32
Manual Disconnect .....	32
Safety Warnings .....	11, 19, 31, 32
<b>Opener Terminals</b>	
Door Control Connections .....	18
Safety Reversing Sensor Connections .....	23
Outside Keylock Accessory Connections .....	18
<b>Operational Noise</b>	
Sprocket noise .....	11
Vibration noise (isolator kit) .....	34
<b>Protector System®</b> .....	21, 30
<b>Receiver and Remote Controls</b>	
Programming the receiver .....	33
Erasing all codes .....	33
Safety warning .....	33
Problems with remote control operation .....	34
<b>Safety Reverse Test Procedure</b> .....	30
Testing required .....	11, 30, 34, 35
Safety Reverse System Problems	
Securing header bracket to wall .....	12
Adjusting travel limits .....	28
Applying excessive force on the door .....	29
Buckling or uneven floor .....	4, 5
<b>Safety Warnings</b> .....	2, 3, 9, 11, 12, 16, 18, 19, 20, 21, 24, 28, 29, 30, 31, 32, 33
<b>User Instruction Label for garage wall</b> .....	11, 18

# LIFT-MASTER SERVICE IS ON CALL

OUR LARGE SERVICE ORGANIZATION  
SPANS AMERICA

INSTALLATION AND SERVICE INFORMATION IS AS  
NEAR AS YOUR TELEPHONE SIX DAYS A WEEK.  
SIMPLY DIAL OUR TOLL FREE NUMBER:

**1-800-528-2817**

HOURS: (Mountain Std. Time)  
6:00 A.M. TO 6:00 P.M. - Monday through Friday  
7:00 A.M. TO 3:00 P.M. - Saturday  
Closed Sunday

For professional installation, parts and service,  
contact your local LIFT-MASTER/ CHAMBERLAIN  
dealer. Look for him in the Yellow Pages, or call our  
Service number for a list of dealers in your area.

# HOW TO ORDER REPAIR PARTS

Selling prices will be furnished on request or parts will  
be shipped at prevailing prices and you will be billed  
accordingly.

WHEN ORDERING REPAIR PARTS, ALWAYS GIVE  
THE FOLLOWING INFORMATION:

- PART NUMBER
- PART NAME
- MODEL NUMBER

ADDRESS ORDERS TO:  
THE CHAMBERLAIN GROUP, INC.  
Parts and Service Department  
2301 N. Forbes Boulevard, Suite 104  
Tucson, Arizona 85745

SERVICE INFORMATION  
TOLL FREE NUMBER:  
**1-800-528-2817**

## LIFT-MASTER GARAGE DOOR OPENER ONE-YEAR LIMITED WARRANTY

The Chamberlain Group, Inc. ("Seller") warrants to the first retail purchaser of this product, for the residence in which this product is originally installed, that it will be free from any defect in materials and/or workmanship for a period of one year from the date of purchase. The product must be used in complete accordance with Chamberlain's instructions for installation, operation and care. **The proper operation of this product is dependent on your compliance with the Owner's Manual instructions regarding installation, operation, maintenance and testing. Failure to comply strictly with those instructions will void this warranty in its entirety. Please note that the safety reverse system, in order to operate properly with your garage door, must be adjusted and periodically tested in accordance with the Owner's Manual.**

If, during the limited warranty period, it appears as though this product contains a defect which is covered by this limited warranty, **CALL OUR TOLL FREE SERVICE NUMBER, BEFORE DISMANTLING THIS PRODUCT, AT (1-800-528-2817).** Then send this product, pre-paid and insured, to our service center for warranty repair. You will be advised of shipping instructions when you call the toll free service number. Please include a brief description of the problem and a dated proof-of-purchase receipt with any product that is returned for warranty repair.

Products returned to Seller for warranty repair, which upon receipt by Seller are confirmed to be defective and covered by this limited warranty, will be repaired or replaced (at Seller's sole option) at no cost to you and returned pre-paid. Defective parts will be repaired or replaced with new or factory-rebuilt parts at Seller's sole option.

**THIS LIMITED WARRANTY IS IN LIEU OF ANY OTHER WARRANTIES, EXPRESS OR IMPLIED, INCLUDING ANY IMPLIED WARRANTY OF MERCHANTABILITY OR FITNESS FOR A PARTICULAR PURPOSE, OR OTHERWISE, AND OF ANY OTHER OBLIGATIONS OR LIABILITY ON SELLER'S PART. THIS LIMITED WARRANTY DOES NOT COVER NON-DEFECT DAMAGE, DAMAGE CAUSED BY IMPROPER INSTALLATION, OPERATION OR CARE (INCLUDING, BUT NOT LIMITED TO ABUSE, MISUSE, FAILURE TO PROVIDE REASONABLE AND NECESSARY MAINTENANCE, OR ANY ALTERATIONS TO THIS PRODUCT), LABOR CHARGES FOR DISMANTLING OR REINSTALLING A REPAIRED OR REPLACED UNIT, REPLACEMENT OF BATTERIES AND LIGHT BULBS, OR UNITS INSTALLED FOR NON-RESIDENTIAL USE.**

**THIS LIMITED WARRANTY DOES NOT COVER ANY PROBLEMS WITH, OR RELATING TO, THE GARAGE DOOR OR GARAGE DOOR HARDWARE, INCLUDING BUT NOT LIMITED TO THE DOOR SPRINGS, DOOR ROLLERS, DOOR ALIGNMENT AND HINGES. ANY SERVICE CALL THAT DETERMINES THE PROBLEM HAS BEEN CAUSED BY ANY OF THESE ITEMS COULD RESULT IN A FEE TO YOU.**

**UNDER NO CIRCUMSTANCES SHALL SELLER BE LIABLE FOR CONSEQUENTIAL, INCIDENTAL OR SPECIAL DAMAGES ARISING IN CONNECTION WITH THE USE OF, OR INABILITY TO USE, THIS PRODUCT. IN NO EVENT SHALL SELLER'S LIABILITY FOR BREACH OF WARRANTY, BREACH OF CONTRACT, NEGLIGENCE OR STRICT LIABILITY EXCEED THE COST OF THE PRODUCT COVERED HEREBY. NO PERSON IS AUTHORIZED TO ASSUME FOR US ANY OTHER LIABILITY IN CONNECTION WITH THE SALE OF THIS PRODUCT.**

Some states do not allow the exclusion or limitation of consequential, incidental or special damages, so the above limitation or exclusion may not apply to you. This limited warranty gives you specific legal rights, and you may also have other rights which vary from state to state.

### LIMITED WARRANTY ON MOTOR

**Models 1256R & 1255R:** The motor is warranted to be free from any defect in materials and/or workmanship for a period of 48 full months (4 years) from the date of purchase.

**Models 1246R & 1245R:** The motor is warranted to be free from any defect in materials and/or workmanship for a period of 24 full months (2 years) from the date of purchase.

**Model 1240R:** The motor is warranted to be free from any defect in materials and/or workmanship for a period of 12 full months (1 year) from the date of purchase.